



Psych Congress

KEEPING THE PATIENT IN MIND:

Novel Stimulant Treatment Approaches
in Adult Patients with ADHD

*This activity has been supported through an independent
educational grant from Noven Pharmaceuticals, Inc.*

Faculty

Rakesh Jain, MD, MPH

Clinical Professor

Department of Psychiatry

Texas Tech University School of Medicine

Midland, Texas



Faculty Disclosures

- **Dr. Rakesh Jain:** Advisory Board—Adamas, Alkermes, Corium, Eisai, Indivior, Intra-Cellular Therapies, Ironshore Pharmaceuticals, Janssen, Lilly, Lundbeck, Merck, Neos Therapeutics, Neurocrine Biosciences, Otsuka, Pamlab, Pfizer, Shire, Sunovion, Supernus, Takeda, Teva, Tris Pharmaceuticals; Advisory Board (spouse)—Otsuka; Consultant—AbbVie (Allergan), Acadia, Adamas, Alfasigma USA, Inc., Axsome, Corium, Cingulate Therapeutics, Eisai, Evidera, Impel NeuroPharma, Janssen, Lilly, Lundbeck, Merck, Neos Therapeutics, Neurocrine Biosciences, Osmotica, Otsuka, Pamlab, Pfizer, Sage Therapeutics, Shire, Sunovion, Supernus, Takeda, Teva; Consultant (spouse)—Lilly, Otsuka, Pamlab, Sunovion; Grant/Research Support—AbbVie (Allergan), Lilly, Lundbeck, Otsuka, Pfizer, Shire, Takeda; Speakers Bureau—AbbVie (Allergan), Alkermes, Axsome, Corium, Eisai, Indivior, Intracellular Therapies, Ironshore Pharmaceuticals, Janssen, Lilly, Lundbeck, Merck, Neos Therapeutics, Neurocrine, Otsuka, Pamlab, Pfizer, Shire, Sunovion, Takeda, Teva, Tris Pharmaceuticals; Speakers Bureau (Spouse)—Lilly.

Disclosure

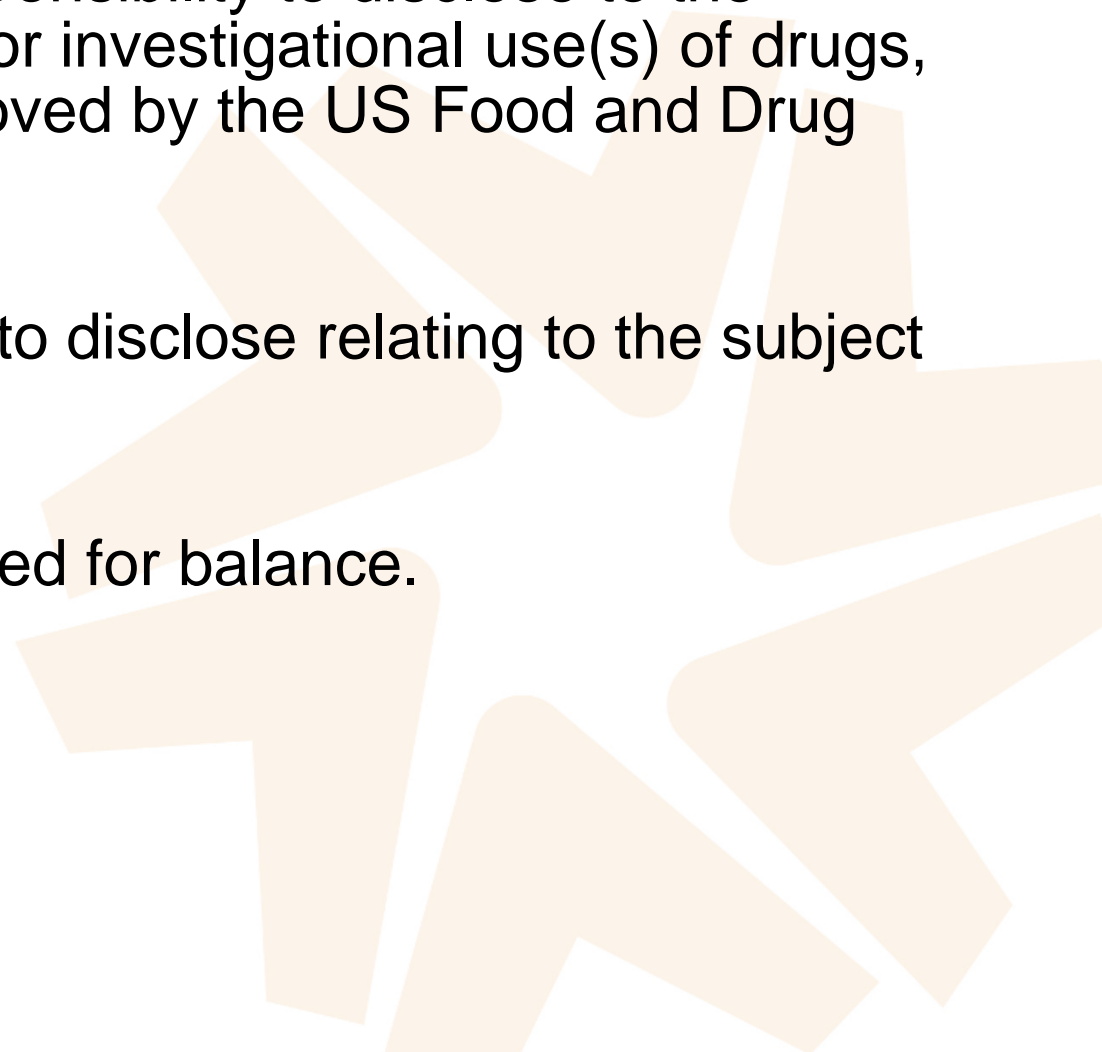
- The faculty have been informed of their responsibility to disclose to the audience if they will be discussing off-label or investigational use(s) of drugs, products, and/or devices (any use not approved by the US Food and Drug Administration).
 - Applicable CME staff have no relationships to disclose relating to the subject matter of this activity.
 - This activity has been independently reviewed for balance.
- 

Learning Objectives

- Implement appropriate diagnostic criteria to identify adult patients with ADHD
- Evaluate the current stimulant treatment landscape and its limitations for optimal management of adult patients with ADHD
- Assess adult patients with ADHD for potential stimulant misuse and abuse
- Integrate knowledge of the pharmacological properties, mechanisms of action, and routes of administration of novel stimulants for treatment of adult patients with ADHD
- Incorporate shared decision-making into development of patient-centered treatment plans that support maximizing coverage and providing flexibility of coverage for adult patients with ADHD

*Introduction: Epidemiology, Diagnosis,
Longitudinal Course, Impairments*



ADHD Is Prevalent in All Age Groups

Historically, ADHD has been thought of as a childhood disorder, but it has been demonstrated to persist into adulthood



**8% of
children
have ADHD**



**6% of
adolescents
have ADHD**

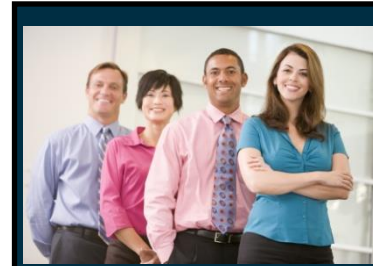

**4.4% of
adults
have ADHD**



**2.8% of
seniors
have ADHD**

**Up to 65% of children with ADHD continue
to experience the disorder into adulthood¹**

How the Public Sees ADHD and Adult ADHD

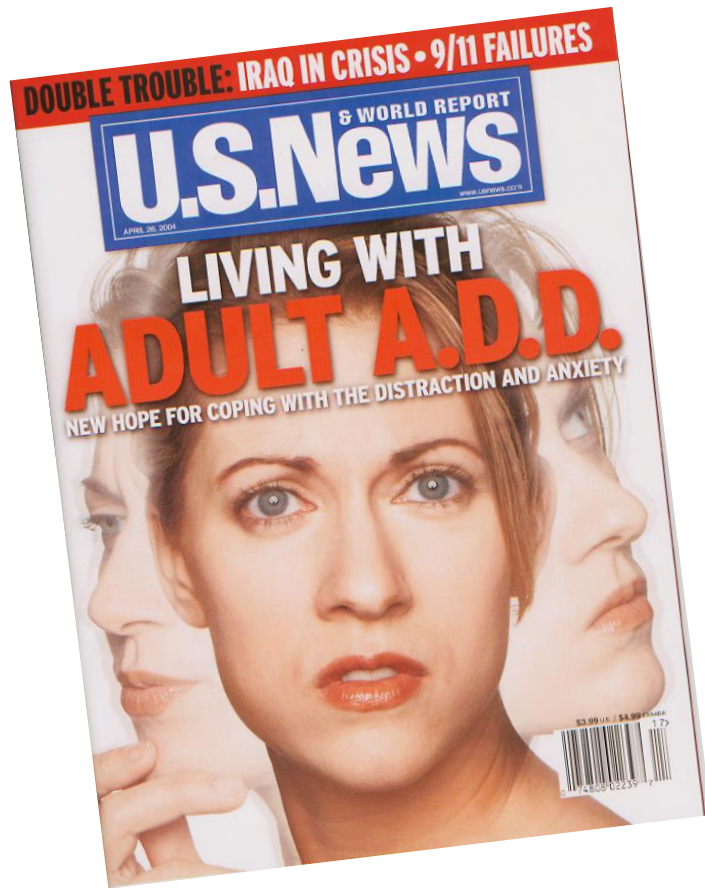

Is Adult ADHD a Common Disorder?
Emphatically, It Is. And It Is Highly Impairing



Prevalence of ADHD in Adulthood

This meta-regression analysis indicated that the pooled prevalence of ADHD in adulthood across sample was 2.5%

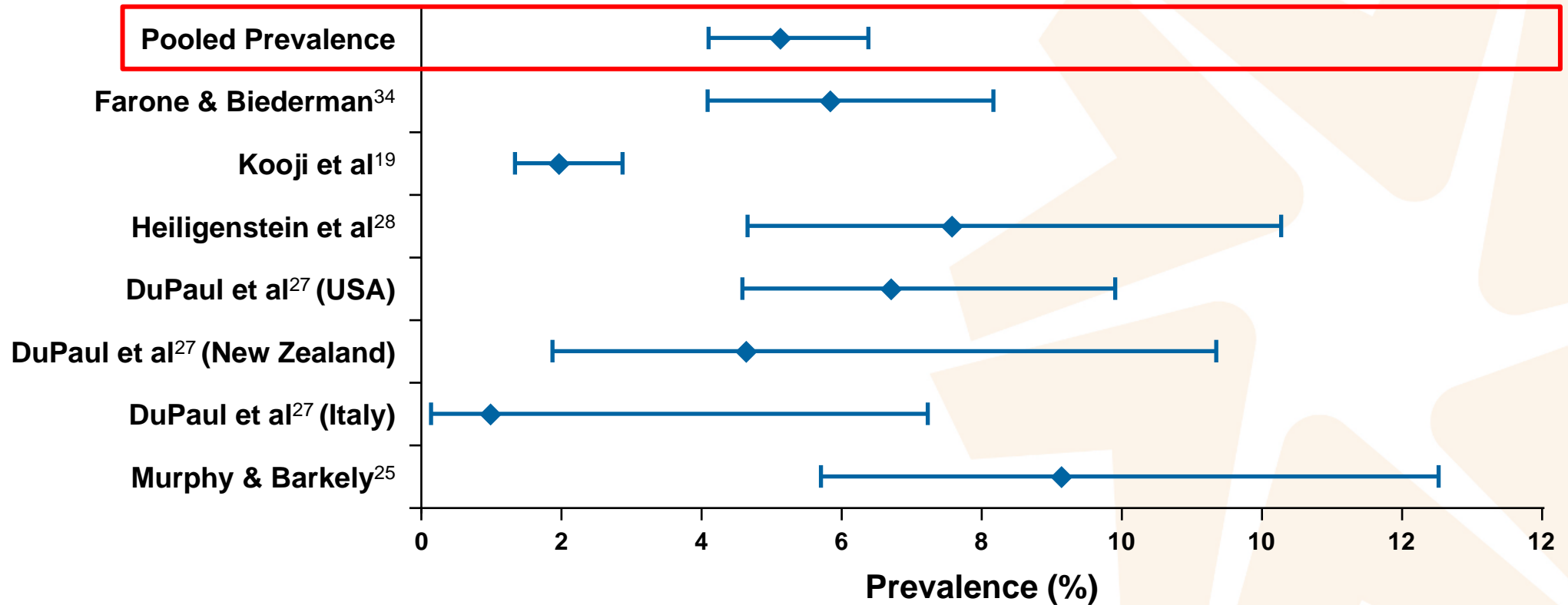

Patients with ADHD Have Greater Rates of Functional Impairment

Functional Impairments in ADHD vs Normal Control

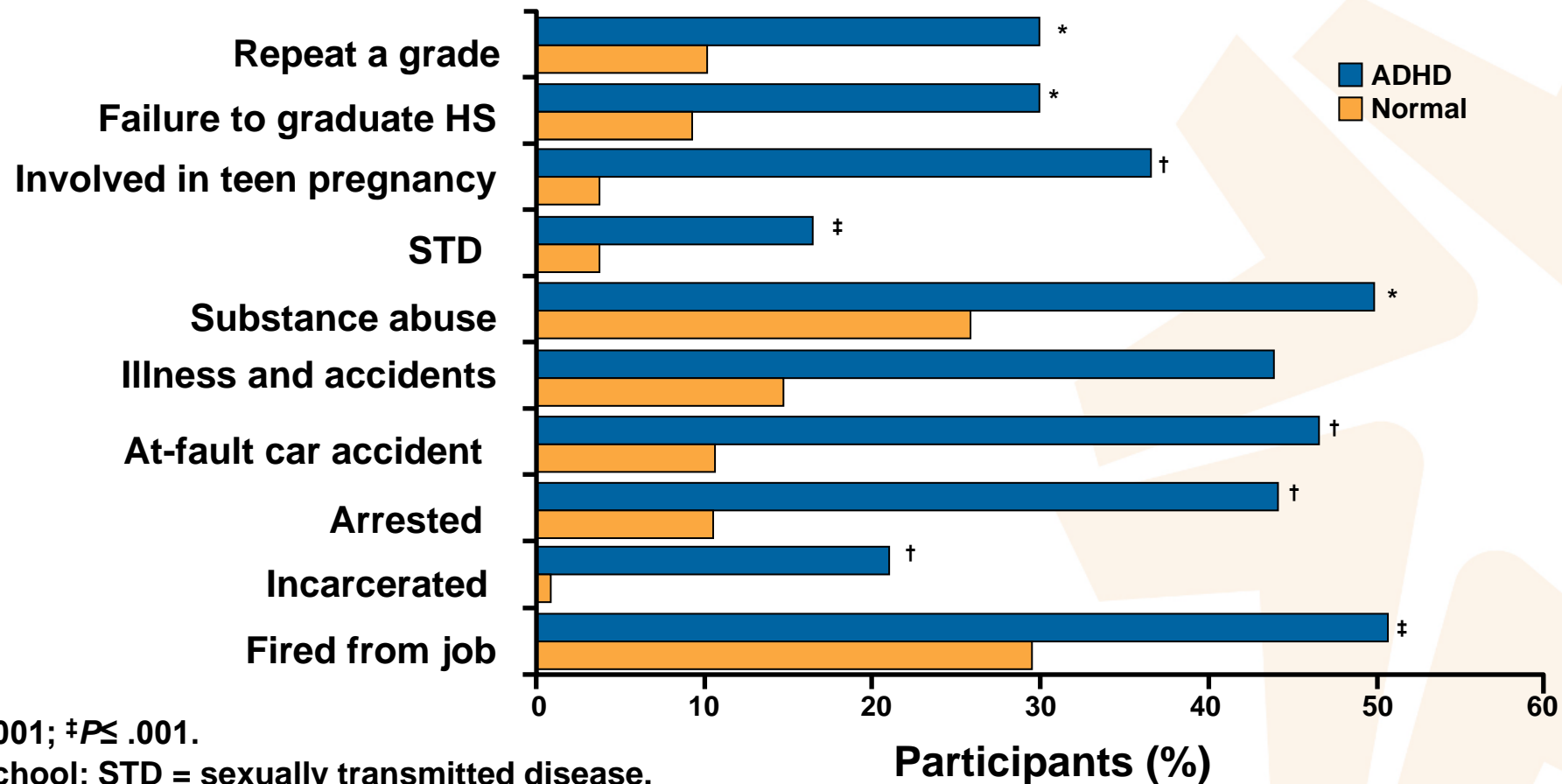

* $P \leq .01$; † $P \leq .001$; ‡ $P \leq .001$.

HS = high school; STD = sexually transmitted disease.

Steele M, et al. *Clin Ther.* 2006;28(11):1892-1908.

Mortality in ADHD increases with the number of psychiatric comorbidities

Relative Mortality Risk compared to Control Cohort

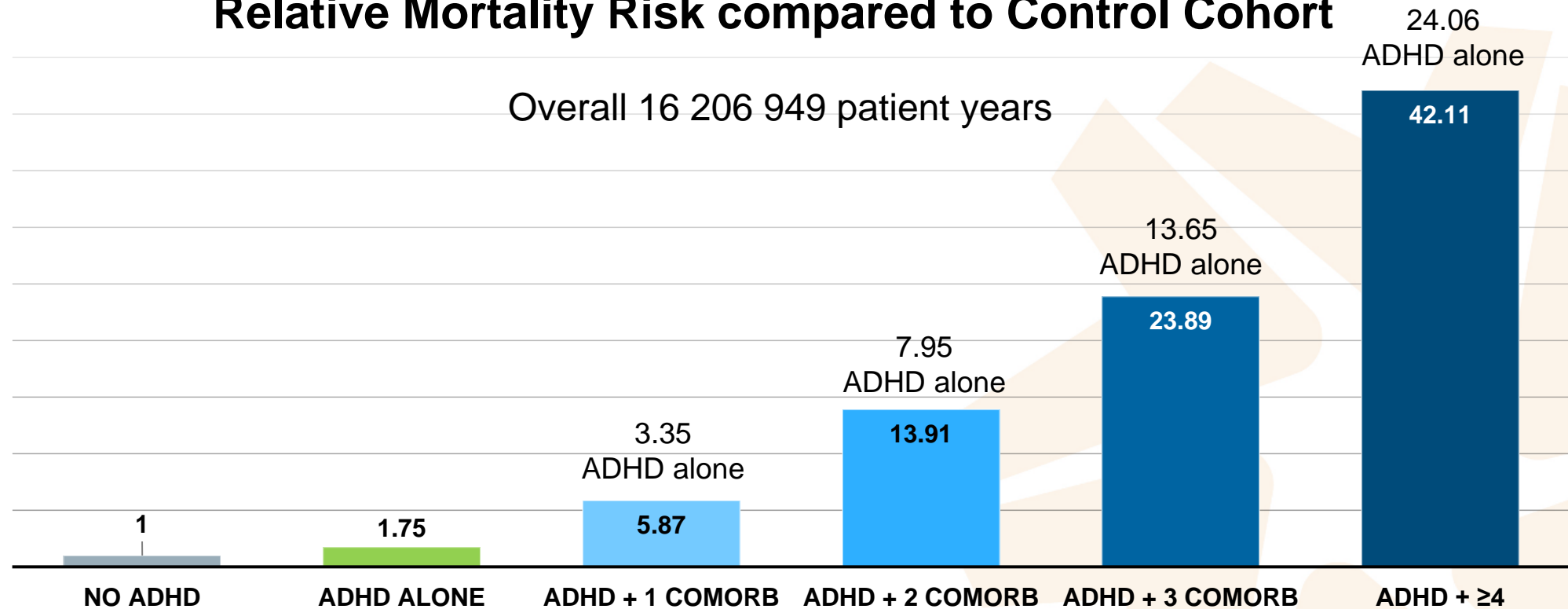

2 675 615 individuals born in Sweden from January 1, 1983, through December 31, 2009

Motor Vehicle Trauma and ADHD Medication Usage

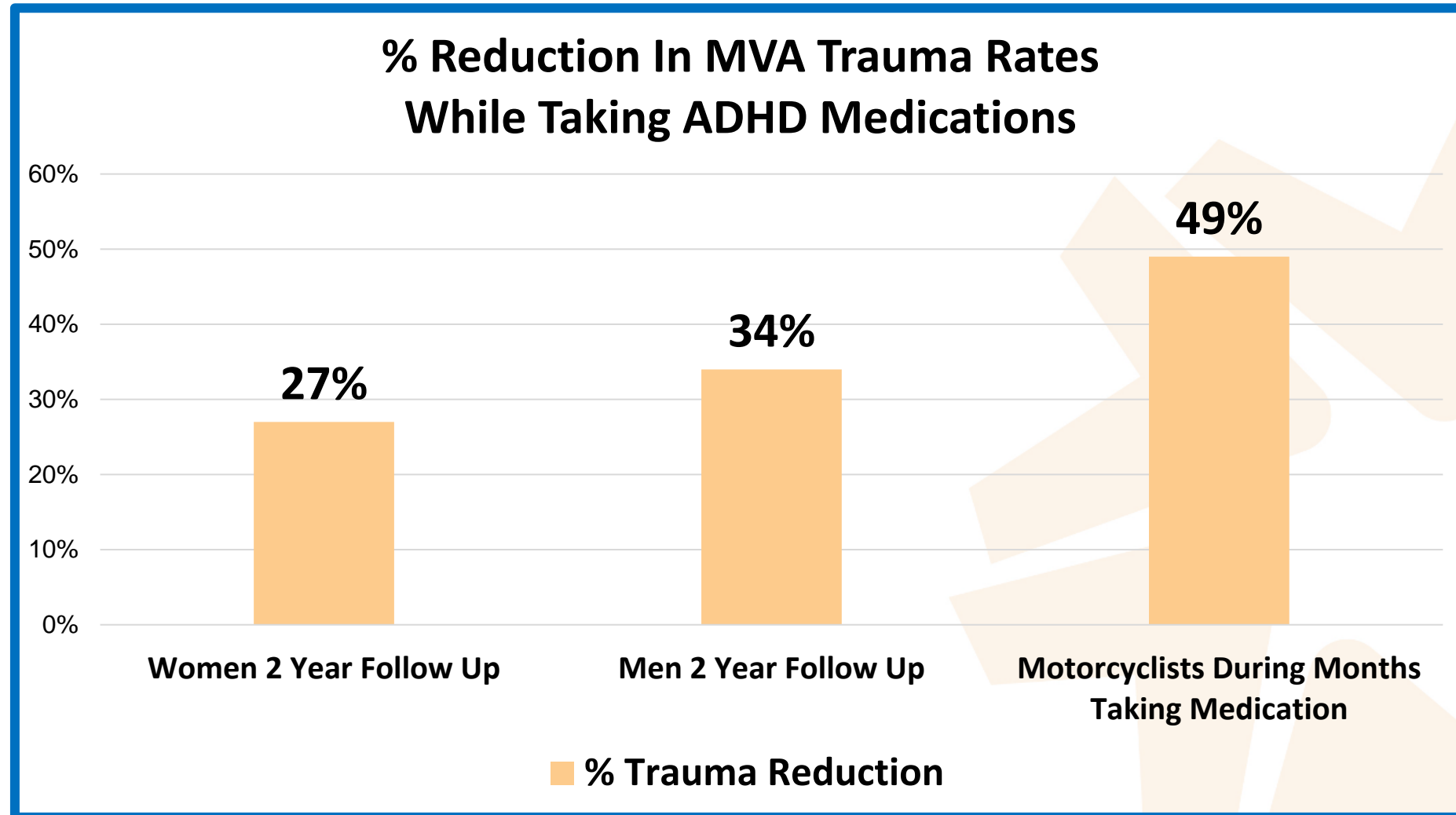

Potential Areas of Impairment in Adults with ADHD



Whom Should We Screen?

- **Patients presenting with:**
 - Family history or children with ADHD
 - Treatment resistant MDD, Bipolar, or Anxiety Disorders
 - Drug abuse or drug dependence
 - Poor school performance as a child (not reaching potential)
 - Poor occupational performance as an adult (not reaching potential)
 - Motor vehicle issues
 - Forgetfulness (missed appointments, trouble with adherence to medications)

Why is ADHD Missed?

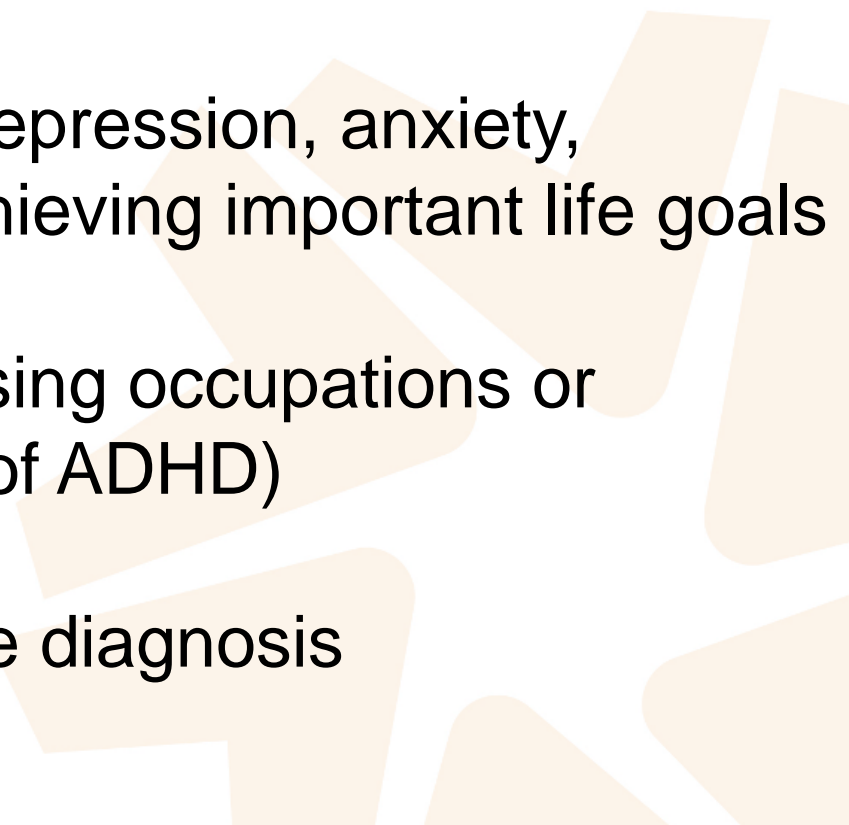
- Lack of knowledge on part of patients and clinicians
 - Presenting complaints often involve depression, anxiety, substance abuse and/or problems achieving important life goals
 - Compensatory strategies – (eg, choosing occupations or relationships that mitigate symptoms of ADHD)
 - Stigma – negative attitudes toward the diagnosis
 - Public opinion
 - Medical bias
- 
- A graphic consisting of several overlapping, stylized handprints in a light orange color, arranged in a circular pattern on the right side of the slide.

Adult ADHD & Co-morbidities & Screening for ADHD



Adult ADHD Comorbidities Can Complicate Things, but a Stepwise Manner of Differential Diagnosis Leads to Success

- However, 50% to 70%, with estimates as high as 80%, of Adults with ADHD have at least one distinct comorbid psychiatric disorder
- Substance Abuse: 15.2%
- Mood Disorders: 38.3%
- Bipolar Disorder: 19.4%
- Anxiety Disorders: 47.1%

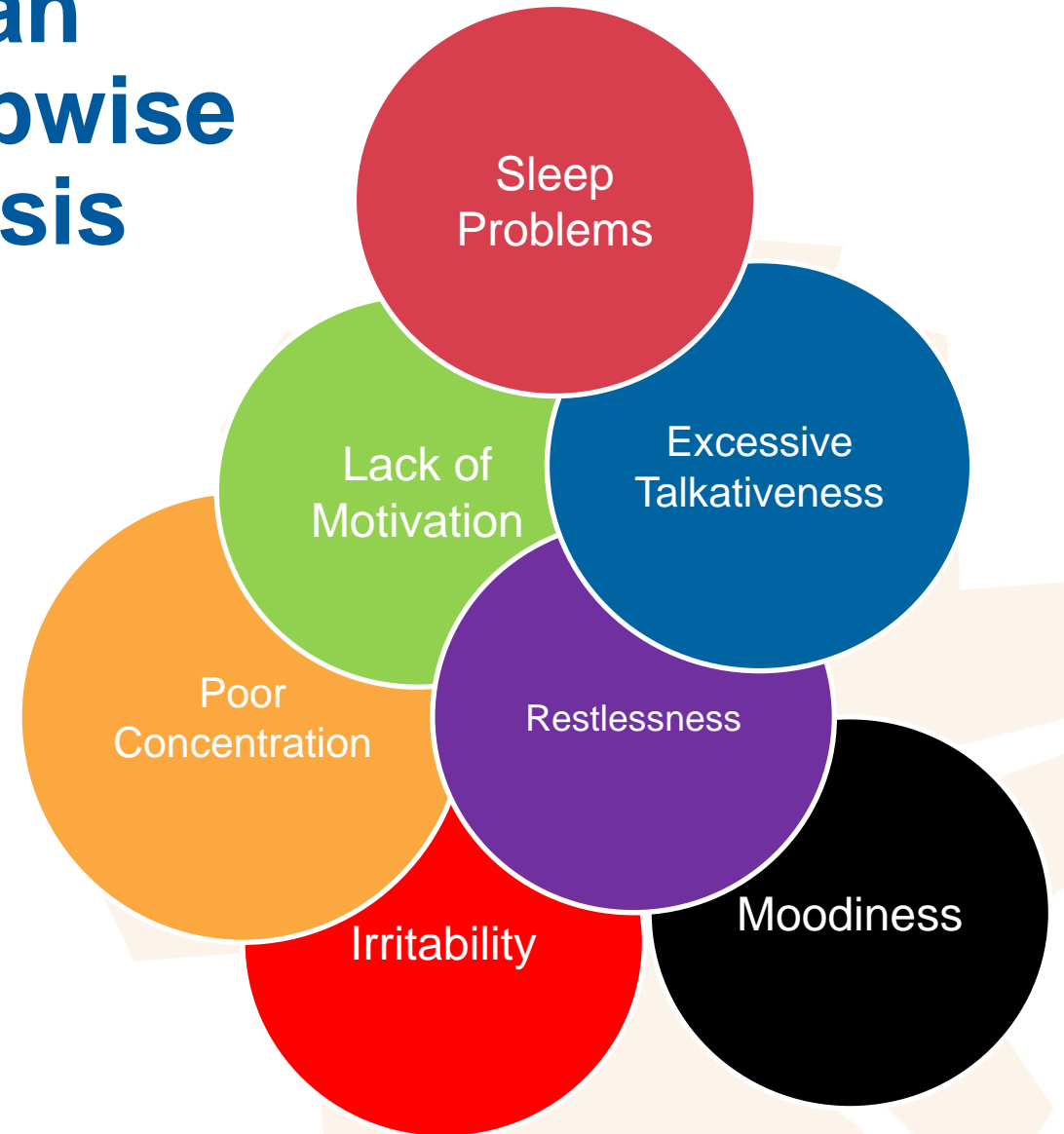

The Presentation of ADHD May Go Beyond Core Symptoms – *Importance of Thinking About Co-morbidities*

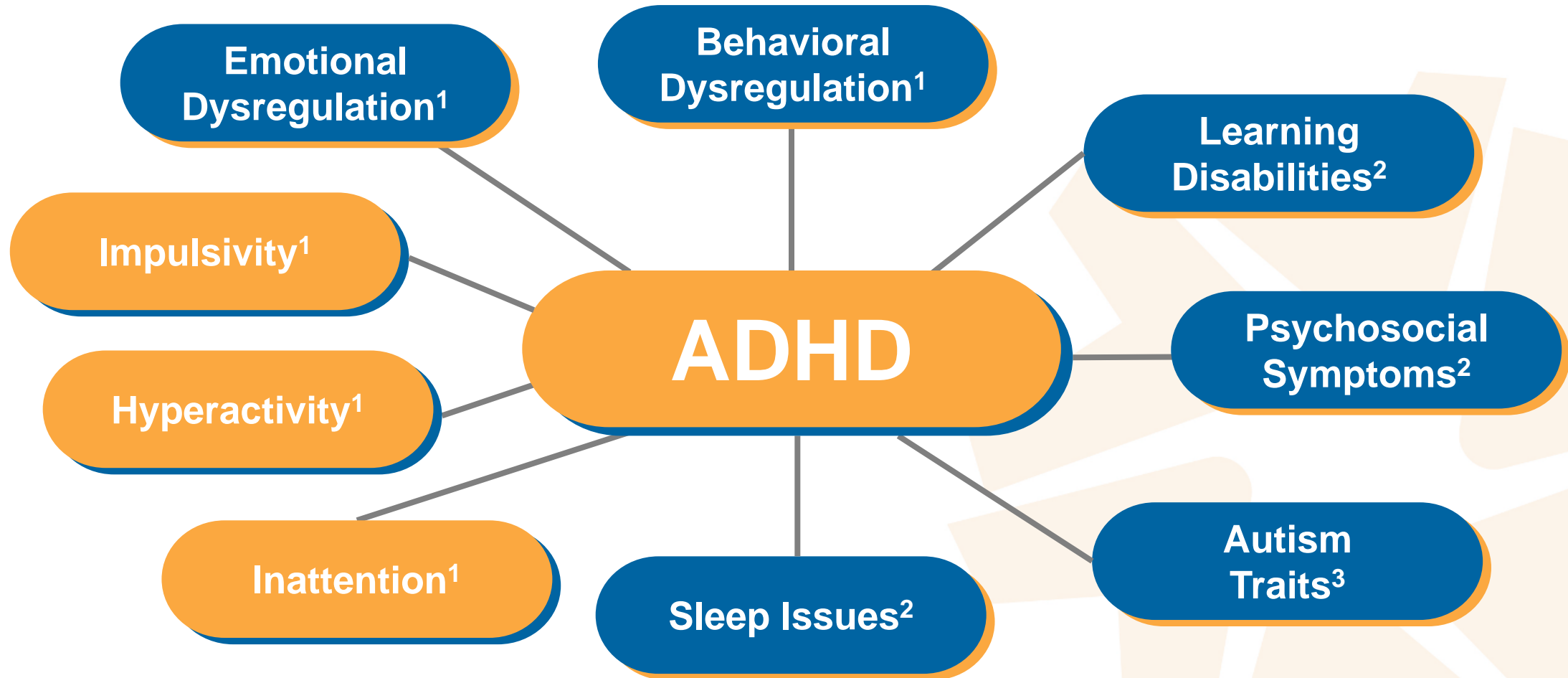

1. American Psychiatric Association. *Diagnostic and Statistical Manual of Mental Disorders, 5th Edition*. Arlington, VA: American Psychiatric Association; 2013. 2. Barbaresi WJ et al. *J Dev Behav Pediatr*. 2020;41(suppl):S1-S23. 3. Joshi G et al. *Eur Child Adolesc Psychiatry*. 2019. doi: 10.1007/s00787-019-01384-8.

Adult ADHD is Rarely Alone: *Multiple Comorbidities are the Rule, not Exception*

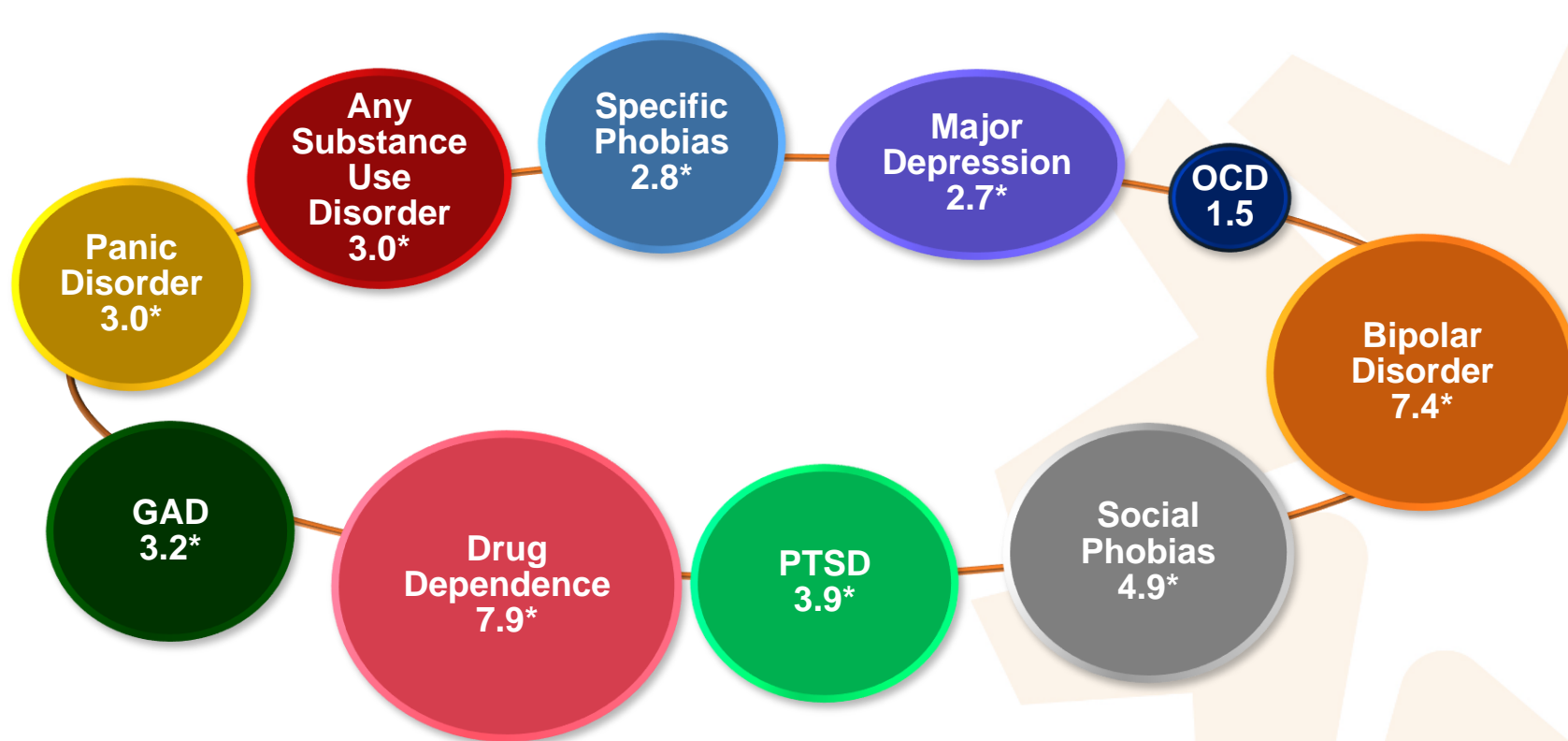

Odds Ratio (95% CI). * $P < .05$.

GAD = generalized anxiety disorder; NCS-R = National Comorbidity Survey Replication; OCD = obsessive-compulsive disorder; PTSD = posttraumatic stress disorder.

Kessler RC, et al. *Am J Psychiatry*. 2006;163(4):716-723.

National Comorbidity Survey Replication: Mood & Anxiety Disorders in Adult ADHD

12-month prevalence rates prior to assessment

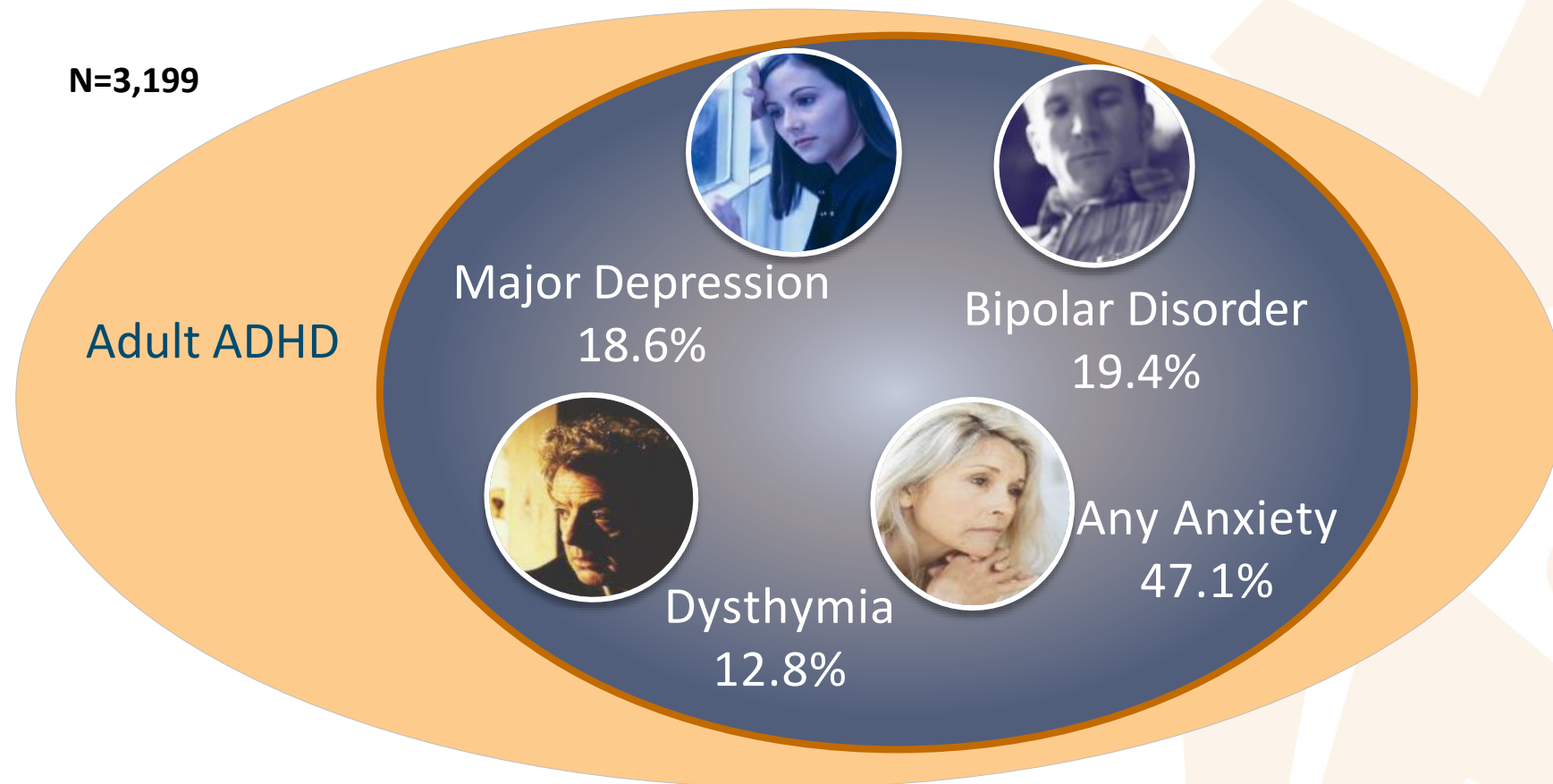

Diagnostic Issues: Getting To The Bottom Of The Right Diagnosis or Diagnoses



Assessing for Comorbidities is an Essential Step In Diagnosing ADHD

Step 1: Symptoms

Determine the presence of symptoms of ADHD

Step 2: Rule Out

Rule out alternative reasons to determine whether symptoms can be attributed to a diagnosis other than ADHD

Step 3: Additional Disorders

Assess for the existence of additional psychiatric disorders and whether they are primary or secondary to ADHD

Caution:

Adults Often Do Not Report Textbook Symptoms!

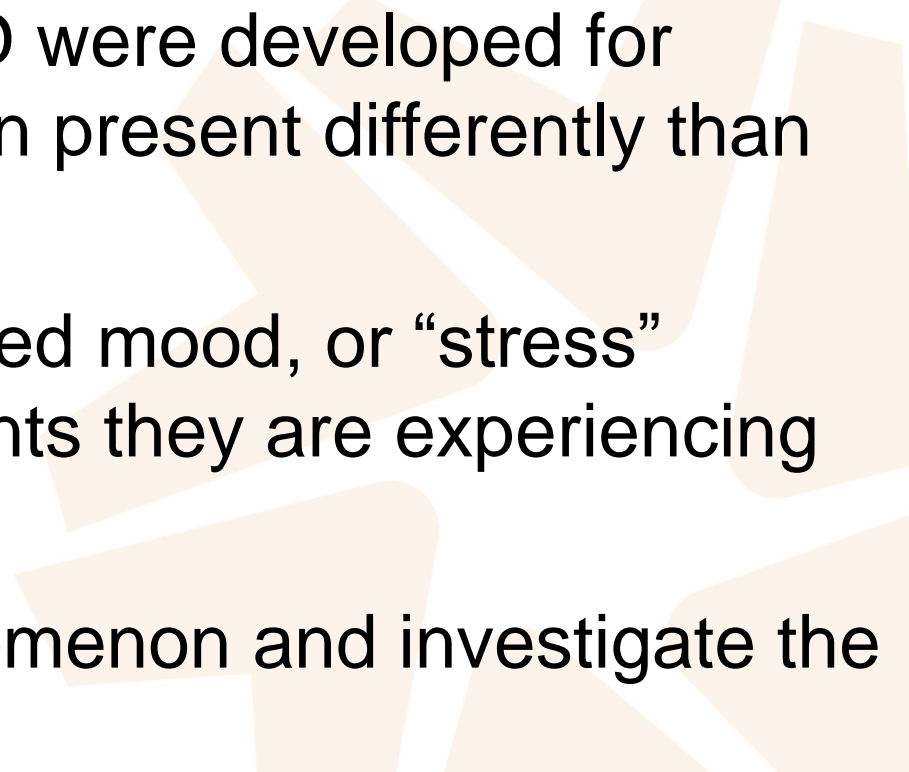
- The *DSM* diagnostic criteria for ADHD were developed for children. Symptoms in adulthood often present differently than childhood symptoms
 - Patients often report anxiety, depressed mood, or “stress” secondary to the functional impairments they are experiencing due to undiagnosed ADHD
 - It is important to recognize this phenomenon and investigate the underlying causes
- 

ADHD Screening Tools

Adult ADHD Self-Report-V1.1 Screener (ASRS-v1.1)

- 6 items in part A
 - If 4 or more Xs in shaded area, positive screen
- 12 items in part B
 - Provides a symptom checklist to further describe areas of impairment
- Sensitivity: 68.7%
- Specificity: 99.5%
- Free and widely available online

ADULT ADHD SELF-REPORT SCALE (ASRS-V1.1) SYMPTOM CHECKLIST

Patient Name _____ Today's Date _____

Please answer the questions below, rating yourself on each of the criteria shown using the scale on the right side of the page. As you answer each question, place an X in the box that best describes how you have felt and conducted yourself over the past 6 months. Please give this completed checklist to your healthcare professional to discuss during today's appointment.

	Never	Rarely	Sometimes	Often	Very Often
PART A					
1. How often do you have trouble wrapping up the final details of a project, once the challenging parts have been done?					
2. How often do you have difficulty getting things in order when you have to do a task that requires organization?					
3. How often do you have problems remembering appointments or obligations?					
4. When you have a task that requires a lot of thought, how often do you avoid or delay getting started?					
5. How often do you fidget or squirm with your hands or feet when you have to sit down for a long time?					
6. How often do you feel overly active and compelled to do things, like you were driven by a motor?					
PART B					
7. How often do you make careless mistakes when you have to work on a boring or difficult project?					
8. How often do you have difficulty keeping your attention when you are doing boring or repetitive work?					
9. How often do you have difficulty concentrating on what people say to you, even when they are speaking to you directly?					
10. How often do you misplace or have difficulty finding things at home or at work?					
11. How often are you distracted by activity or noise around you?					
12. How often do you leave your seat in meetings or other situations in which you are expected to remain seated?					
13. How often do you feel restless or fidgety?					
14. How often do you have difficulty unwinding and relaxing when you have time to yourself?					
15. How often do you find yourself talking too much when you are in social situations?					
16. When you're in a conversation, how often do you find yourself finishing the sentences of the people you are talking to, before they can finish them themselves?					
17. How often do you have difficulty waiting your turn in situations when turn taking is required?					
18. How often do you interrupt others when they are busy?					

Adapted with permission © 2004 World Health Organization

Recent ADHD Guidelines Reflect the Importance of Diagnosing and Treating ADHD Comorbidities: 2020 SDBP

2020 SDBP Guidelines

The clinician with specialized training or expertise should initiate a comprehensive assessment and develop an interprofessional, multimodal treatment plan for any child or adolescent through age 18 years **with suspected or diagnosed complex ADHD** upon referral from a primary care clinician.

Treatment of complex ADHD should include evidence-based approaches that address ADHD and **account for coexisting conditions** while respecting family background and preferences.

- **Complex ADHD is defined by any of the following:**
 - **Presence or suspicion of coexisting disorders and complicating factors***
 - **Moderate to severe functional impairment**
 - **Diagnostic uncertainty on the part of the PCC**
 - **Inadequate response to treatment (or uncertainty about treatment planning)**
 - **Aged <4 years or >12 years at initial symptom presentation**

Novel Stimulant Treatment Options in Adult Patients With ADHD



Pharmacologic and Nonpharmacologic Treatment Options are Used for Treating Adult ADHD



Nonpharmacologic
treatment options^{1,2}

Coaching

Cognitive behavioral therapy

Dialectical behavioral therapy

Physical exercise

Mindful awareness practice



Pharmacologic
treatment options¹

Stimulants

Nonstimulants

In Adult ADHD Patients, Stimulants are Often First Line

(and both classes of stimulants have their place in treatment)

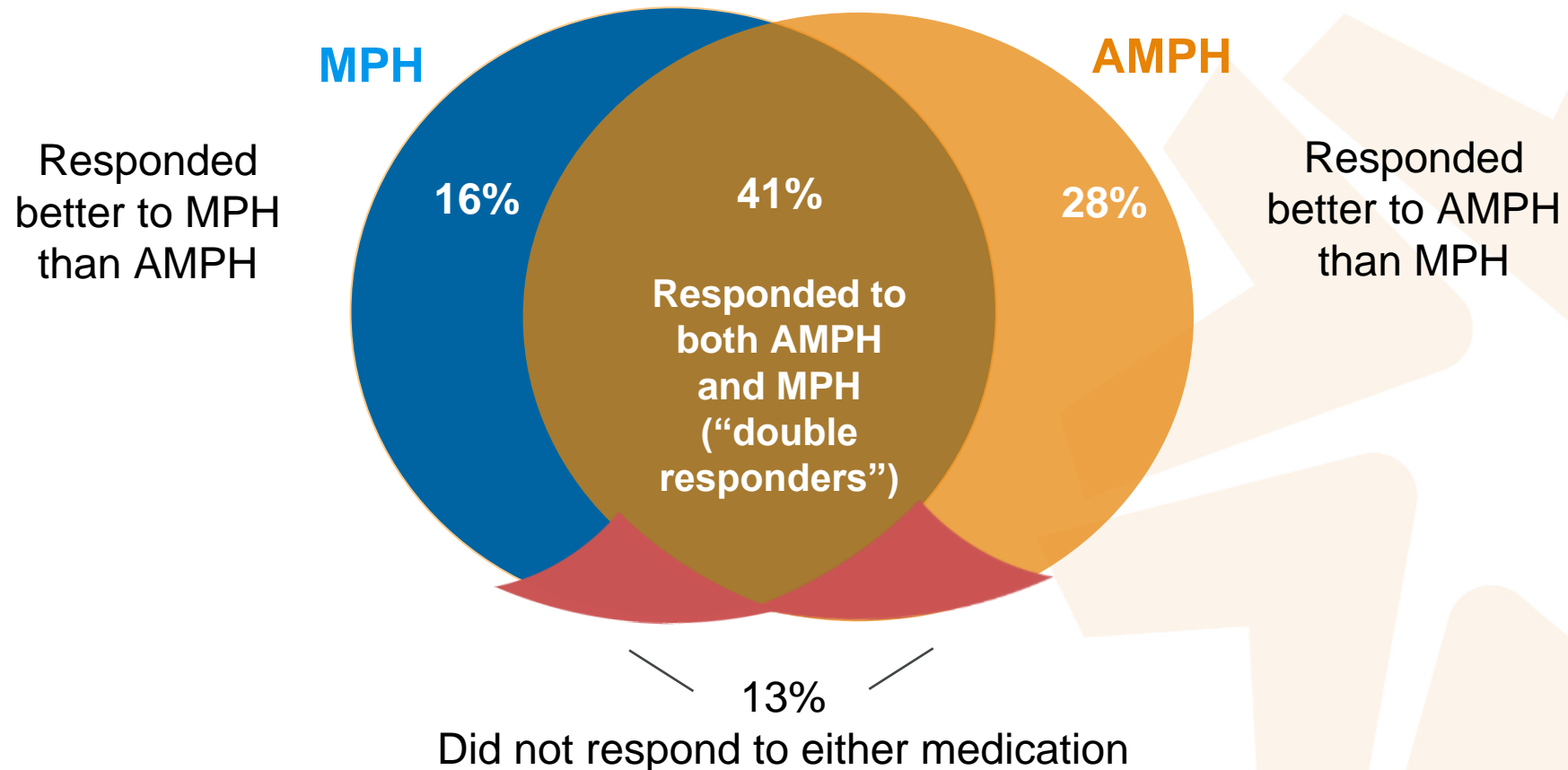

Stimulants Act Via Multiple Mechanisms of Action

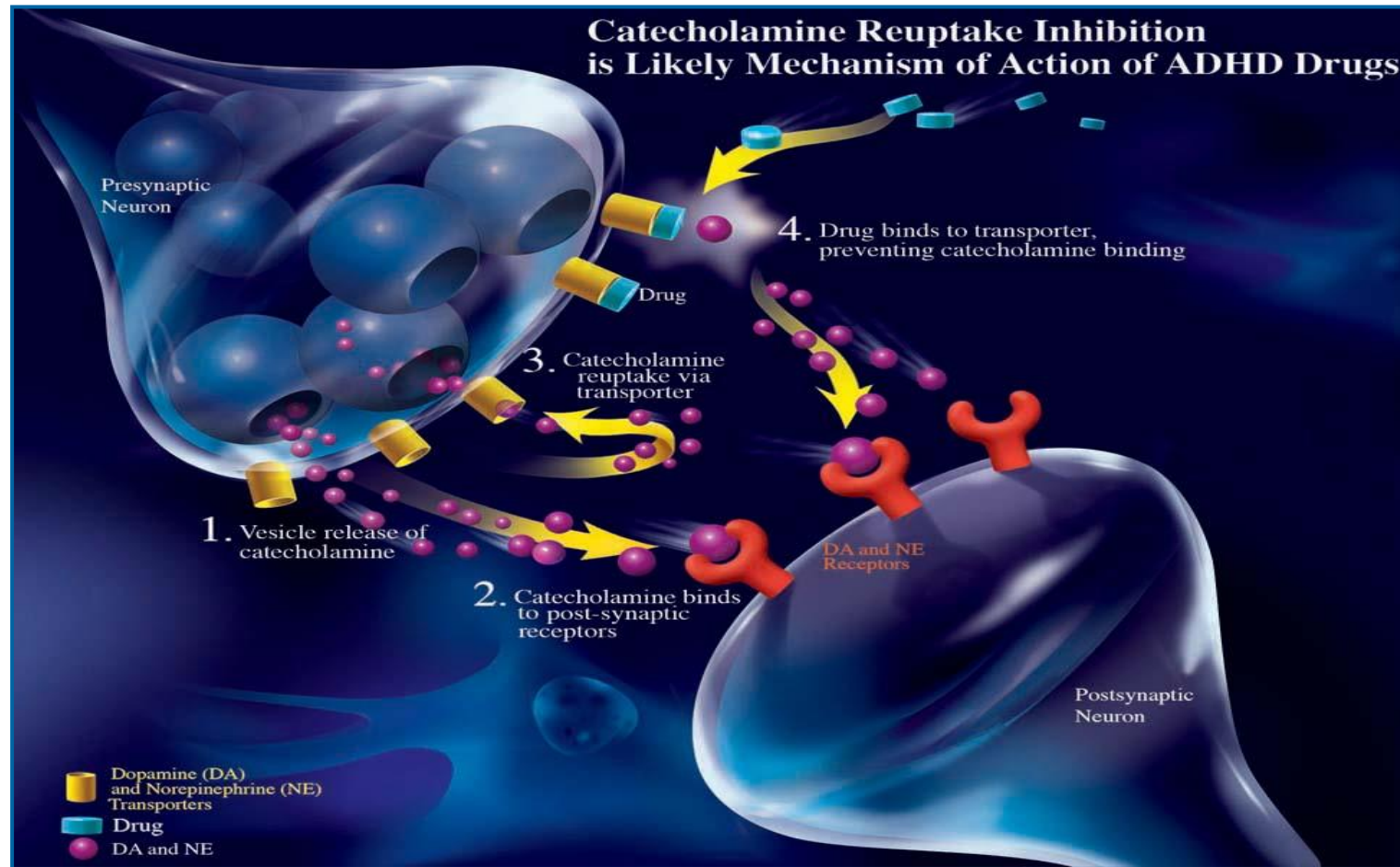

1. Biederman J, Spencer T. *Biol Psychiatry*. 1999;46:1234-1242. Matrenza C, et al. *J Psychopharmacol*. 2004;18:21-31. Davids E, et al. *J Pharmacol Exp Ther*. 2002;301:1097-1102.

Currently Approved ADHD Medications Reflect Limited Distinct Approaches for Adult Patients

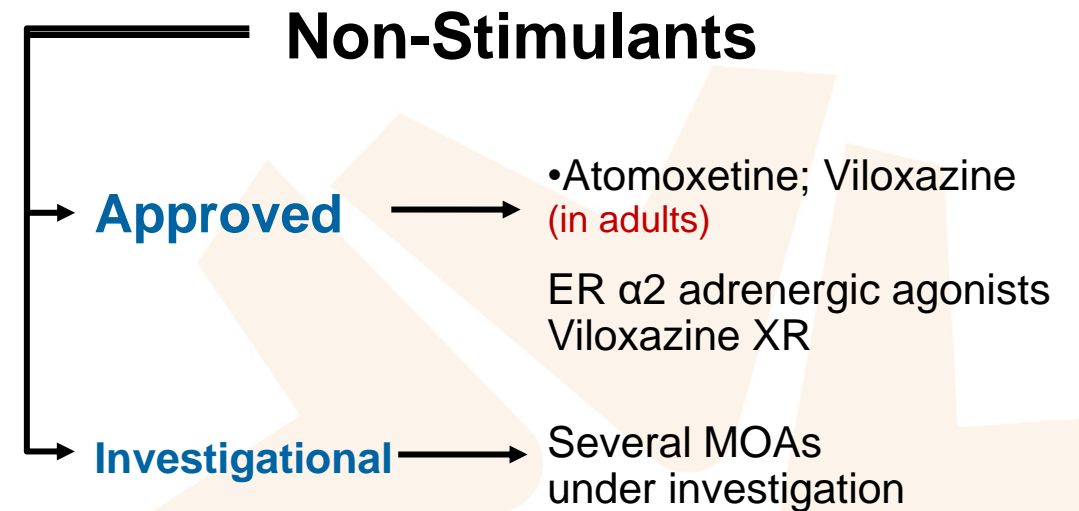
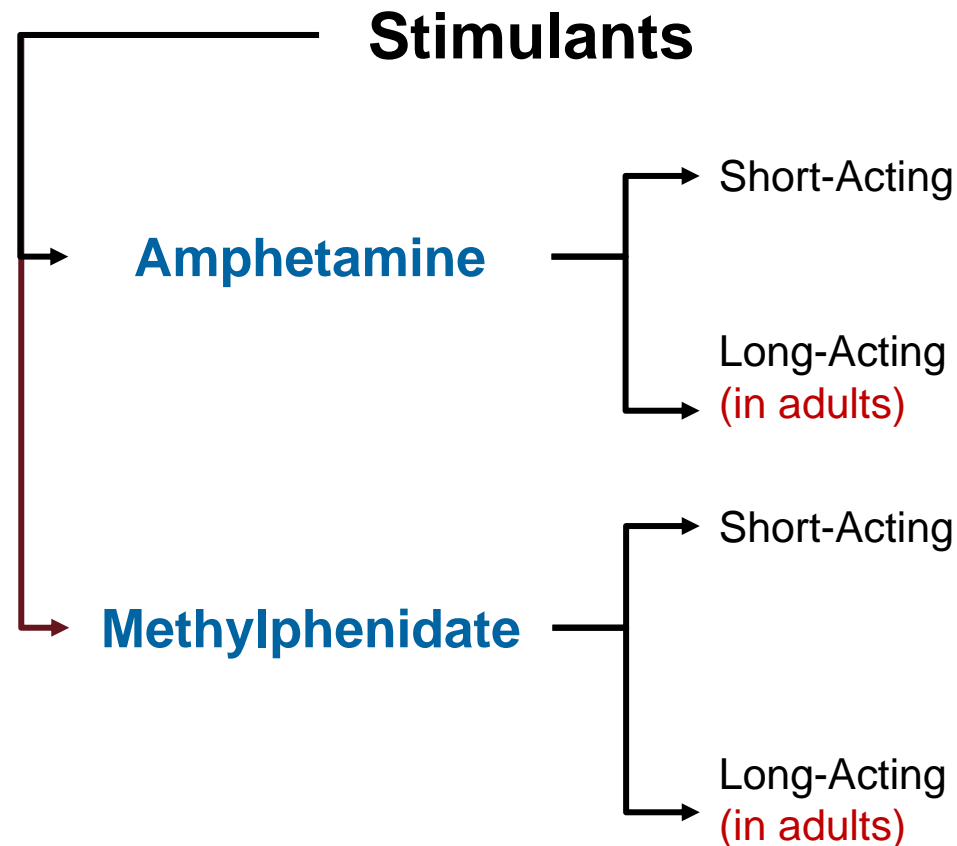

The ADHD Medication Guide. www.adhdmedicationguide.com. US Food and Drug Administration. Drugs@FDA: FDA Approved Drug Products. www.accessdata.fda.gov/scripts/cder/daf/. De Sousa A, et al. *Mens Sana Monogr.* 2012;10(1):45-69. Spencer TJ, et al. *J Clin Psychiatry.* 2002;63 Suppl 12:16-22. Stahl SM, et al. *Prim Care Companion J Clin Psychiatry.* 2004;6(4):159-166. Chang SC, et al. Stimulants, Wakefulness-promoting Agents, and Nonstimulant Attention Deficit Hyperactivity Disorder Medications. *Journal of Experimental and Clinical Medicine.* 2013;5(6). <https://clinicaltrials.gov/>.

Transition from Methylphenidate to Amphetamine Occurs in Adolescence

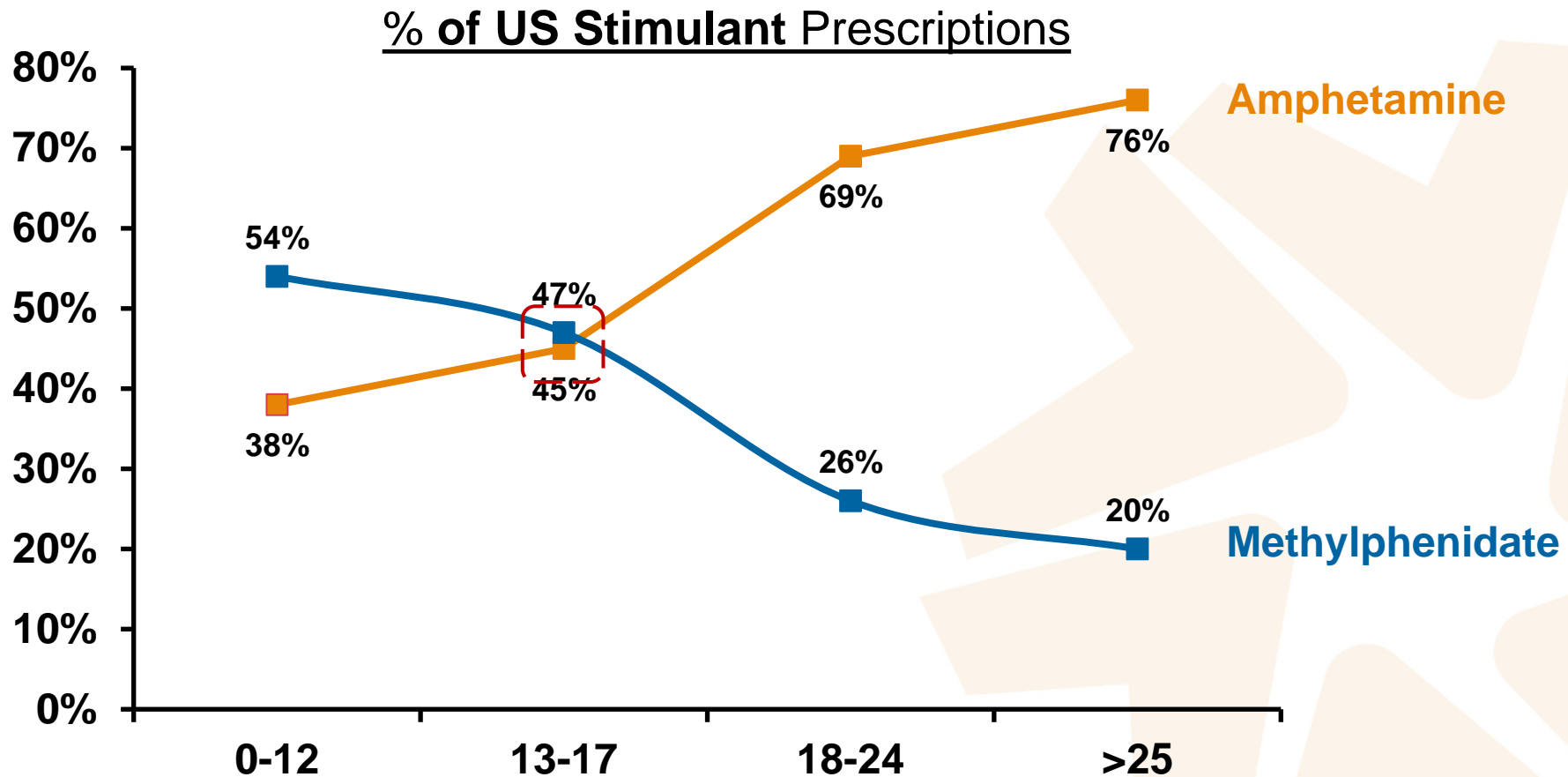

Amphetamine Preparations

Delivery Mechanism and Formulation	Generic Name	Brand Name	Approved Ages	Dosing (per day)	Onset of Effect	Duration of Effect	Comments	References
Short-acting								
Amphetamine tablet	Amphetamine mixed salts	Adderall	Children ≥3	1 to 3	1.5 h	4 to 6 h	Elimination half-life 9.77 to 11 h for the D-isomer and 11.5 to 13.8 h for the L-isomer	65-68
Dextroamphetamine tablet	Dextroamphetamine sulfate	Dexedrine	Children 3 to 16	1 to 2	NA	4 to 6 h		67, 69
Dextroamphetamine tablet	Dextroamphetamine sulfate	Zenzedi	Children 3 to 16	1 to 3	NA	4 to 6 h		70
Dextroamphetamine liquid	Dextroamphetamine sulfate	ProCentra	Children 6 to 16	1 to 2	NA	6 to 10 h	Plasma half-life of approximately 12 h	71
Methamphetamine tablet	Methamphetamine HCL	Desoxyn	Children ≥6	1 to 2	NA	NA	Not readily available	72
Intermediate-acting								
Amphetamine tablet and ODT	Racemic amphetamine sulfate	Evekeo	Children ≥3 (tablet) Children 6 to 17 (ODT)	1 to 2	45 min	9.25 h	Elimination half-life 10.0 to 11.7 h	73-75
Dextroamphetamine capsule	Dextroamphetamine sulfate	Dexedrine spansule	Children 6 to 16	1 to 2	NA	6 to 10 h	Plasma half-life of approximately 12 h	67, 69
Long-acting								
* Amphetamine capsule	Amphetamine mixed salts	Adderall XR	Children ≥6, adults	1	1.5 h	10.5 to 12 h	May be sprinkled on applesauce	53, 54
* Amphetamine liquid	Amphetamine	Adzenys ER	Children ≥6, adults	1	1.5 h	10 to 12 h	Do not add to food or other liquids	55, 56
* Amphetamine ODT	Amphetamine	Adzenys XR-ODT	Children 6 to 12	1	1.5 h	10 to 12 h	Allow tablet to disintegrate in saliva before swallowing	43, 52, 56
Amphetamine liquid	Amphetamine	Dyanavel XR	Children ≥6, adults	1	1 h	12 h		52, 57
* Amphetamine capsule	Amphetamine mixed salts	Mydayis	Children ≥6, adults	1	2 h	14 h	May be sprinkled on applesauce	55, 58
* Amphetamine prodrug capsule and chewable tablet	Lisdexamfetamine dimesylate	Vyvanse	Children ≥6, adults	1	1.5 to 2 h	12 to 14 h	Capsule: may be sprinkled in water, orange juice, or yogurt Chewable tablet: chew thoroughly before swallowing	56, 59

* Approved in adults.

ODT = Oral disintegrating tablet.

Mattingly GW and Young J. *CNS Spectrums*. 2021;26(2), 104-114.

Methylphenidate Preparations

Delivery Mechanism and Formulation	Generic Name	Brand Name	Approved Ages	Dosing (per day)	Onset of Effect	Duration of Effect	Comments	References
Short-acting								
* Dexmethylphenidate tablet	Dexmethylphenidate HCL	Focalin	Children ≥6	2	NA	6 h	At least 4 h between doses	43, 44
* Methylphenidate tablet	Methylphenidate HCL	Ritalin	Children ≥6, adults	2 to 3	1 to 2 h	4 h		45,46
* Methylphenidate chewable tablet and liquid	Methylphenidate HCL	Methylin	Children ≥6, adults	2 to 3	1 h	4 h	Chewable tablet: take with 8 oz of water 30 to 45 min before meals Oral solution: take 30 to 45 min before meals Last dose before 6 PM	47, 48
Intermediate-acting								
* Methylphenidate tablet	Methamphetamine HCL	Methylin ER	Children ≥6, adults	1	NA	NA		49
* Methylphenidate tablet	Methamphetamine HCL	Ritalin-SR	Children ≥6, adults	1	1.5 h	8 h	Take after meals for maximum duration of effect	43, 45
* Methylphenidate tablet	Methamphetamine HCL	Metadate ER	Children ≥6, adults	1	NA	8 h		50
Methylphenidate capsule	Methamphetamine HCL	Metadate CD	Children 6 to 15	1	1.5 h	8 to 9 h	May be sprinkled on applesauce	51, 52
Long-acting								
* Dexmethyl phenidate capsule	Dexmethylphenidate HCL	Focalin XR	Children ≥6, adults	1	30 min	12 h	May be sprinkled	53, 54
* Methylphenidate chewable tablet	Methylphenidate HCL	Quillichew ER	Children ≥6, adults	1	45 min	8 h		55, 56
Methylphenidate chewable tablet	Methylphenidate HCL	Ritalin LA	Children 6 to 12	1	30 min to 1 h	12 h	May be sprinkled	43, 52, 56
* Methylphenidate tablet	Methylphenidate HCL	Concerta	Children ≥6, adults	1	1 to 2 h	10 to 12 h		52, 57
* Methylphenidate liquid	Methylphenidate HCL	Quillivant XR	Children ≥6, adults	1	45 min	12 h	Shake bottle vigorously for 10 s before dispensing	55, 58
Methylphenidate capsule	Methylphenidate HCL	Aptensio XR	Children ≥6, adults	1	1 h	12 h	May be sprinkled	56, 59
* Methylphenidate ODT	Methylphenidate	Cotempla XR-ODT	Children ≥6, adults	1	1 h	12 h	No crushing or chewing Allow to disintegrate in saliva before swallowing	56, 60
Methylphenidate transdermal patch	Methylphenidate	Daytrana	Children ≥6, adults	1	2 h	12 h	Wear for ≤9 h	52, 61
* Methylphenidate capsule	Methylphenidate HCL	Adhansia XR	Children ≥6, adults	1	1 h	13 to 16 h	May be sprinkled and consumed within 10 min	62
* Methylphenidate capsule	Methylphenidate HCL	Jornay PM	Children ≥6, adults	1	8 to 10 h	12+ h	Take in the evening between 6:30 and 9:30 PM for early morning symptom control May be sprinkled	63, 64
* Dexmethyl phenidate capsule	Serdexmethylphenidate	Azstarys	Children ≥6, adults	1	30 min	12+ h	May be sprinkled	

* Approved in adults.

ODT = Oral disintegrating tablet.

Mattingly GW and Young J. *CNS Spectrums*. 2021;26(2), 104-114.

Let Us Now Examine the Data on Some of the
Established and Emergent
Stimulant Treatment in ADHD



OROS MPH in Adult ADHD

Another Effective and Generally Well-Tolerated Treatment Option

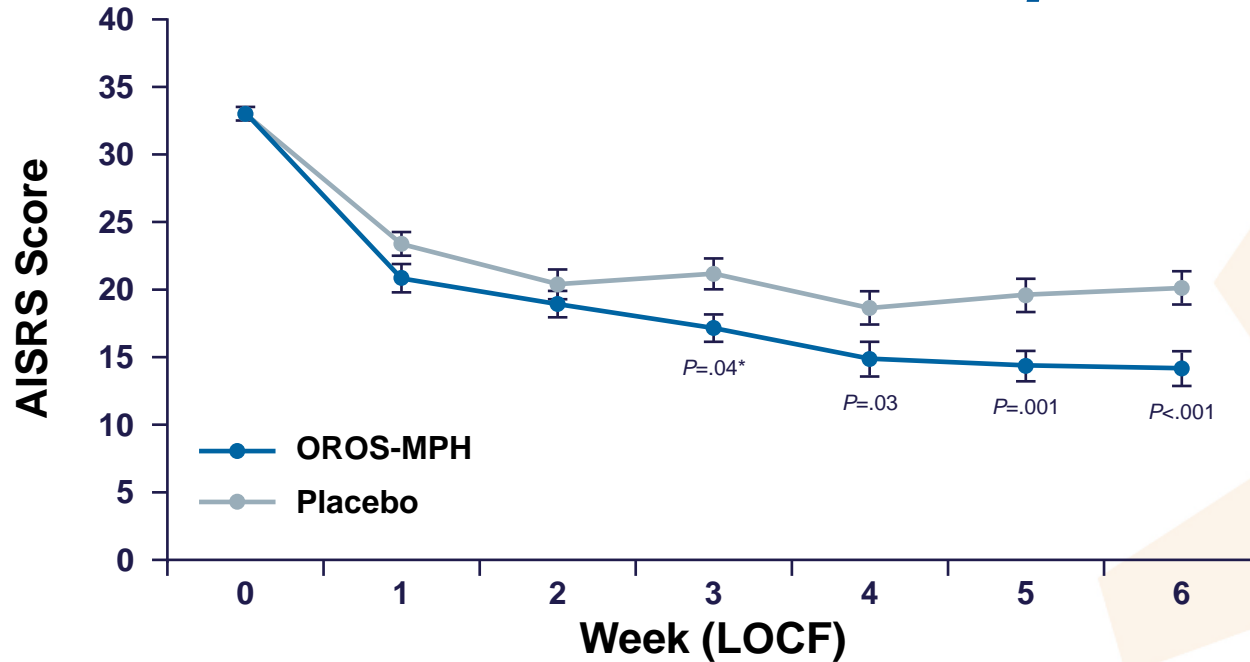

Randomized, multicenter, double-blind, placebo-controlled, with 72 participants randomized to OROS MPH and 77 to placebo

OROS-MPH mg/day	36.0	58.7 ± 17.8	72.6 ± 26.5	77.9 ± 29.6	81.3 ± 31.0	80.9 ± 31.8
Placebo mg/day	36.0	66.3 ± 12.8	82.2 ± 22.4	92.2 ± 23.8	94.9 ± 25.5	96.8 ± 25.9
OROS-MPH mg/kg	0.47 ± 0.14	0.73 ± 0.24	0.89 ± 0.29	0.96 ± 0.30	0.98 ± 0.31	0.99 ± 0.32
Placebo mg/kg	0.47 ± 0.14	0.83 ± 0.23	1.01 ± 0.20	1.12 ± 0.20	1.15 ± 0.20	1.17 ± 0.18

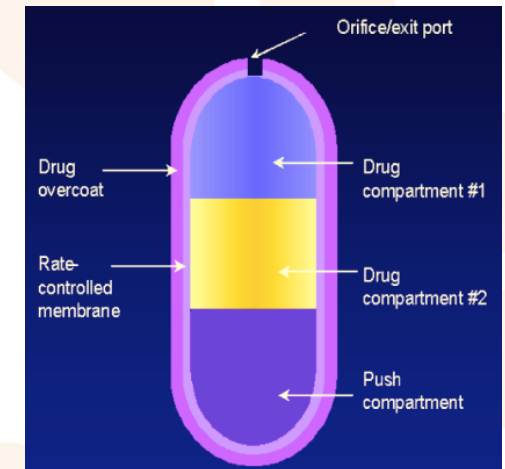

Most common side effects were anorexia, dry mouth, gastrointestinal problems, tension/jitteriness, insomnia, cardiovascular complaints, depression, anxiety, and dizziness

OROS = osmotic release oral system.

Biederman J, et al. *Biol Psychiatry*. 2006;59(9):829-835.

d-MPH-ER in Adult ADHD

Another Effective and Generally Well-Tolerated Treatment Option

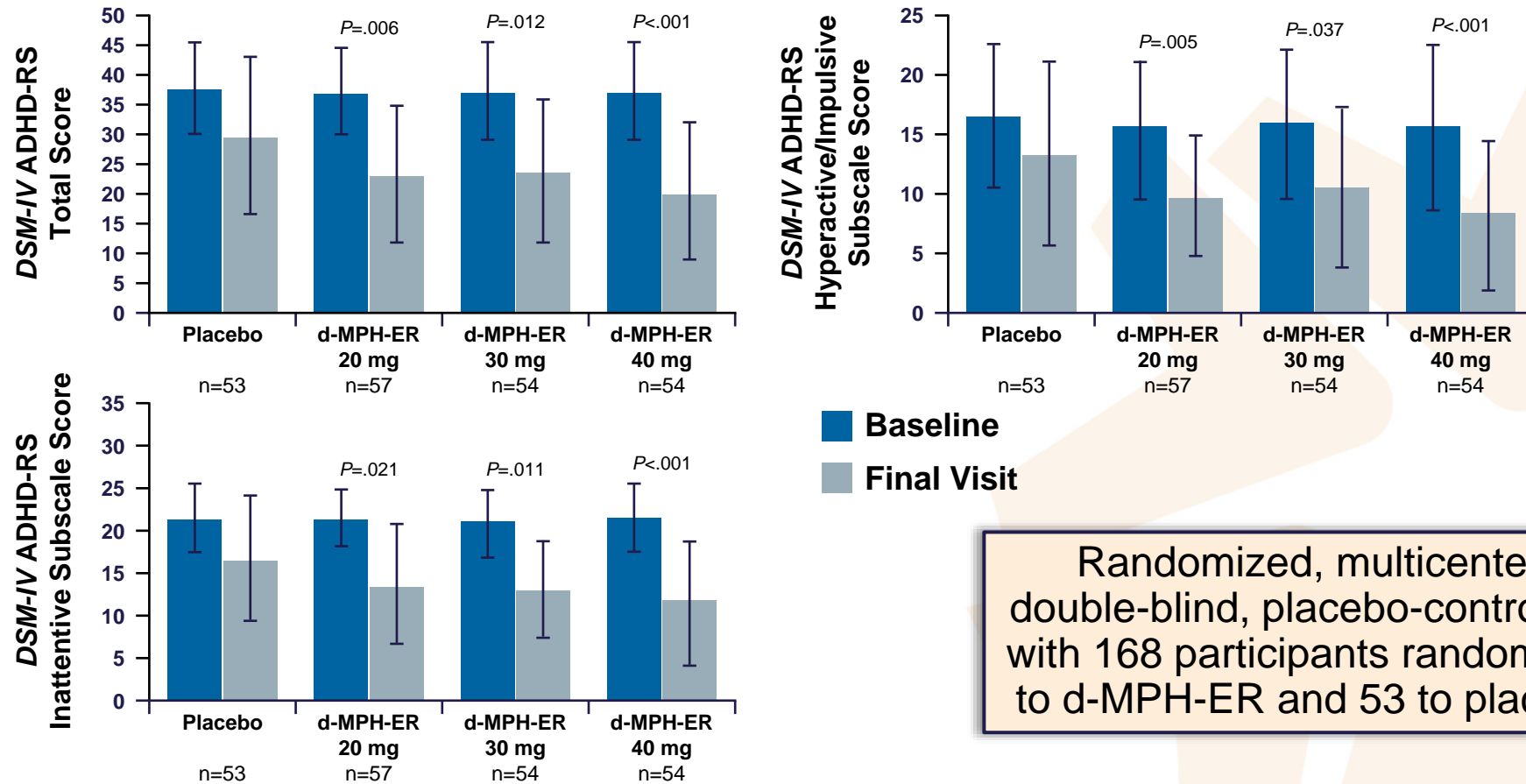

Randomized, multicenter, double-blind, placebo-controlled, with 168 participants randomized to d-MPH-ER and 53 to placebo

Most common side effects were headache, decreased appetite, insomnia, dry mouth, and jitteriness

d-MPH-ER = extended-release dexamethylphenidate.

Spencer TJ, et al. *Biol Psychiatry*. 2007;61(12):1380-1387.

What is a Prodrug?

Lisdexamfetamine is a prodrug that is therapeutically inactive until it is enzymatically converted by enzymes inside the red blood cells into active d-amphetamine in the body

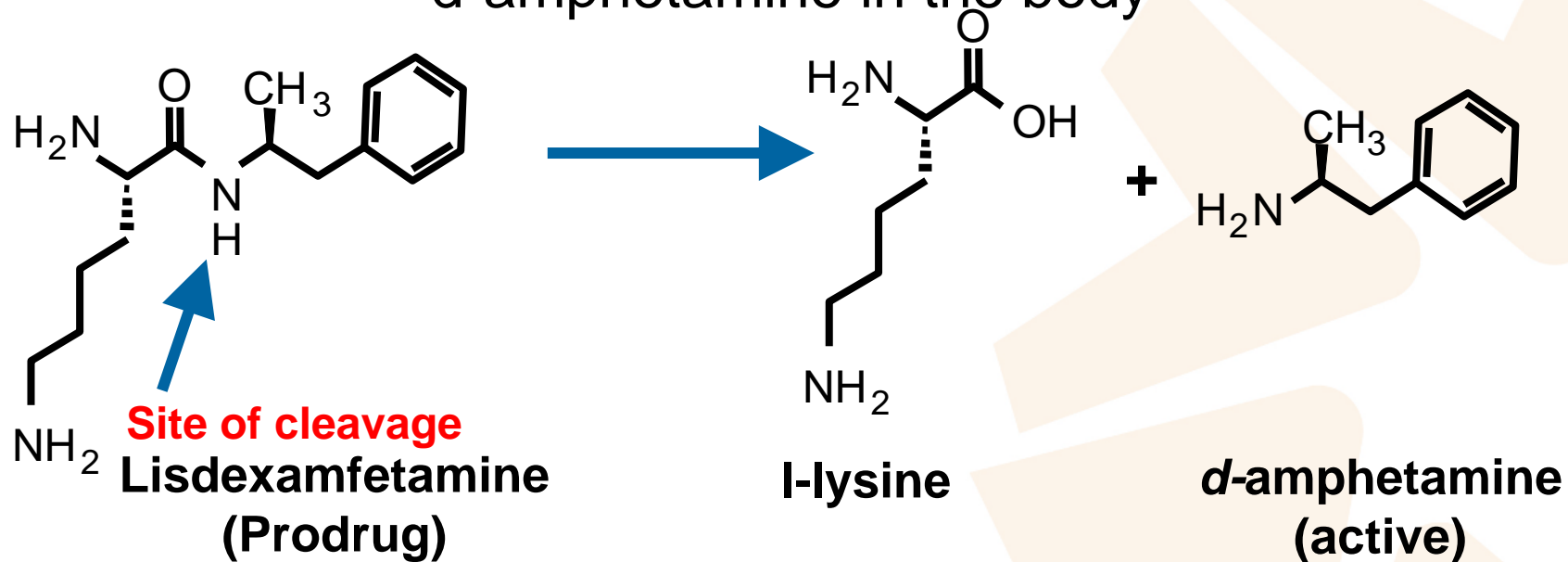

*Release of the active ingredient in lisdexamfetamine does not rely on GI factors such as GI transit time or Gastric pH.
Has been shown to have less "likeability" in abuse potential studies.
No hepatic drug-drug interactions.
14-hour duration of effect in adult workplace studies.*

How Long do They Help?

Modified Workplace Setting PERMP Scores: Lisdexamfetamine vs Placebo

LS Mean PERMP Total Score from 2 to 14 Hours Postdose
(Secondary End Point)

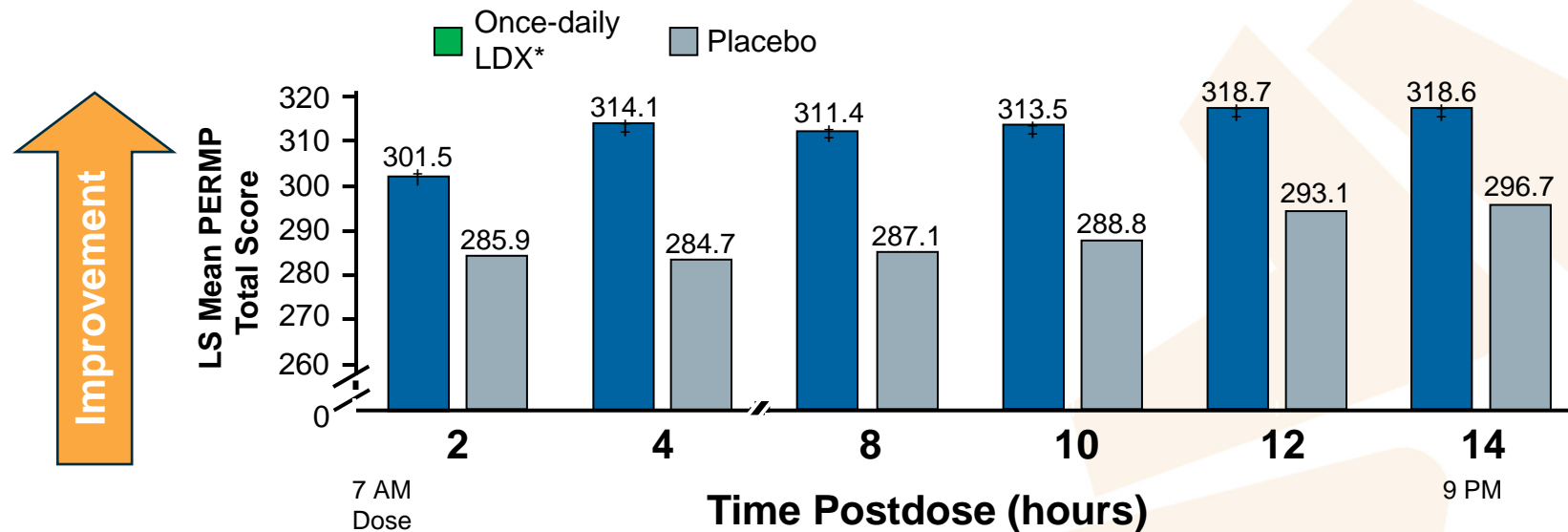

The most common treatment-emergent adverse events ($\geq 5\%$) reported during the dose-optimization phase of this study were decreased appetite, dry mouth, headache, insomnia, upper respiratory tract infection, irritability, nausea, anxiety, feeling jittery, diarrhea, and fatigue

N=104. *Average of all doses tested; † $P=.0017$ vs placebo; ‡ $P<.0001$ vs placebo. LDX = lisdexamfetamine; PERMP = Permanent Product Measure of Performance.

Wigal T, et al. *Behav Brain Funct.* 2010;6:34. Wigal T, et al. Presented at: American Psychiatric Association Institute on Psychiatric Services; October 8–11, 2009; New York, NY.

“Triple Bead” Medication Delivered as Beads Travel Through the Digestive Tract

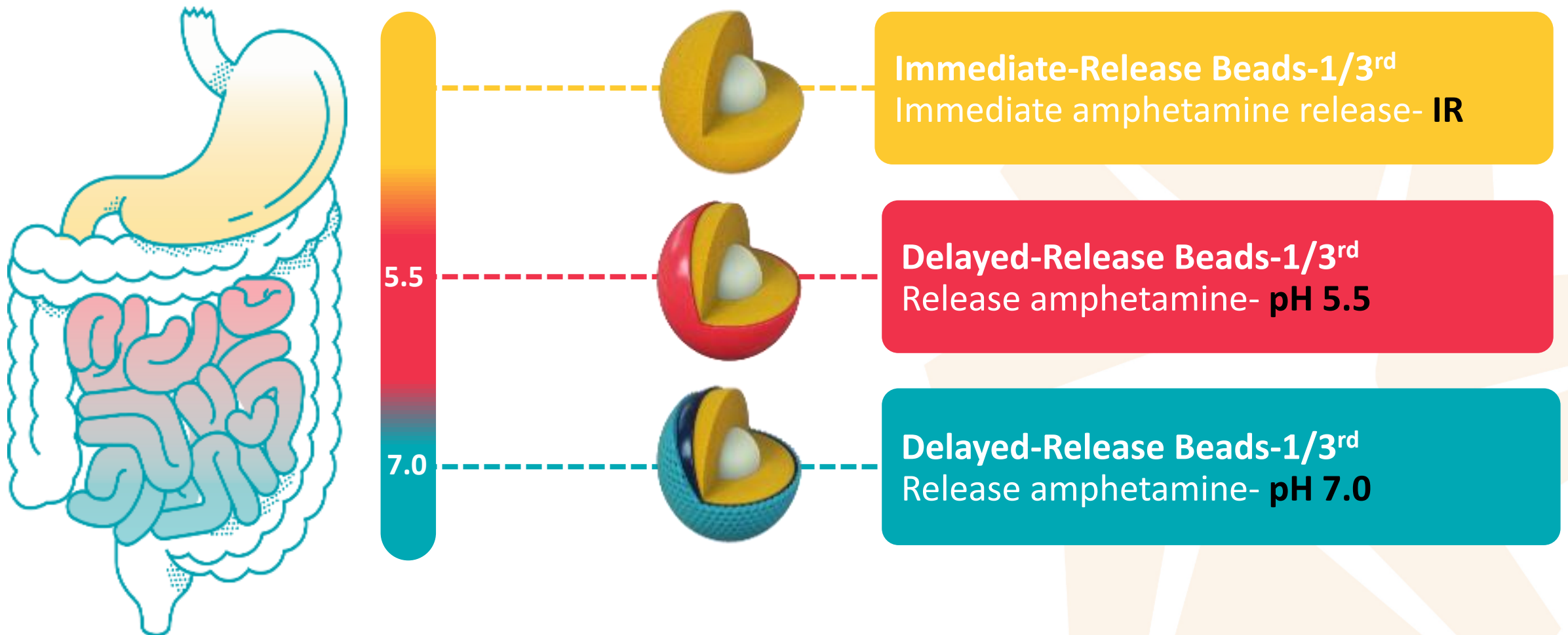

Triple-Bead Formulations of MAS

Another Treatment Option for Adult ADHD

7-week, Phase 3, randomized, double-blind, placebo-controlled, dose optimization study of triple-bead MAS in adults with ADHD (137 randomized to active treatment, 137 randomized to placebo)

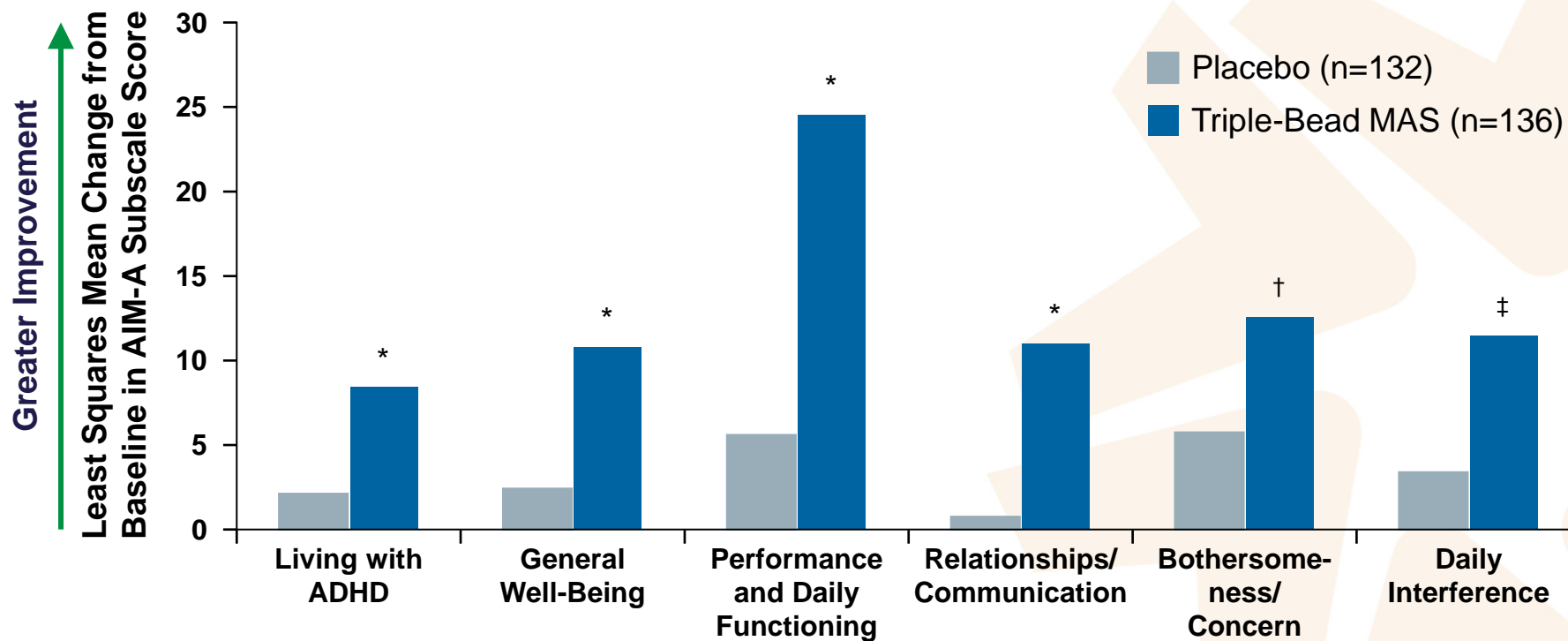

Most common side effects were insomnia, dry mouth, decreased appetite, headache, and decreased weight

* $P < .0001$ vs placebo; † $P = .01$ vs placebo; ‡ $P = .003$ vs placebo. AIM-A = Adult ADHD Impact Module; MAS = mixed amphetamine salts. Spencer TJ, et al. *J Clin Psychiatry*. 2008;69(11):1766-1775.

Another Major Innovation: Combining Delayed Release (DR) with Extended Release (ER)

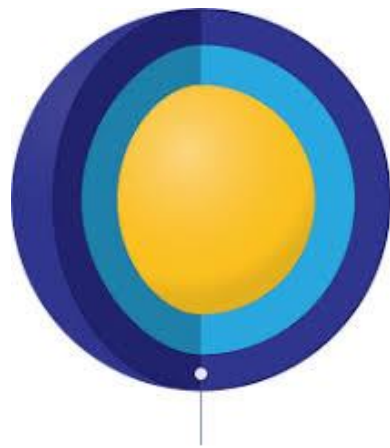

This radically different release medication allows for it be ingested at night, for benefits in AM, and extended during day

Methylphenidate with DR+ER Technology is an Innovative Advance with Demonstrated Benefits

Following a 6-week, open-label titration of DR/ER-MPH to an optimal dose (20, 40, 60, 80, or 100 mg/day) and dosing time (8:00 PM – 1.5 hours), participants were randomized to treatment-optimized DR/ER-MPH or placebo for 1 week

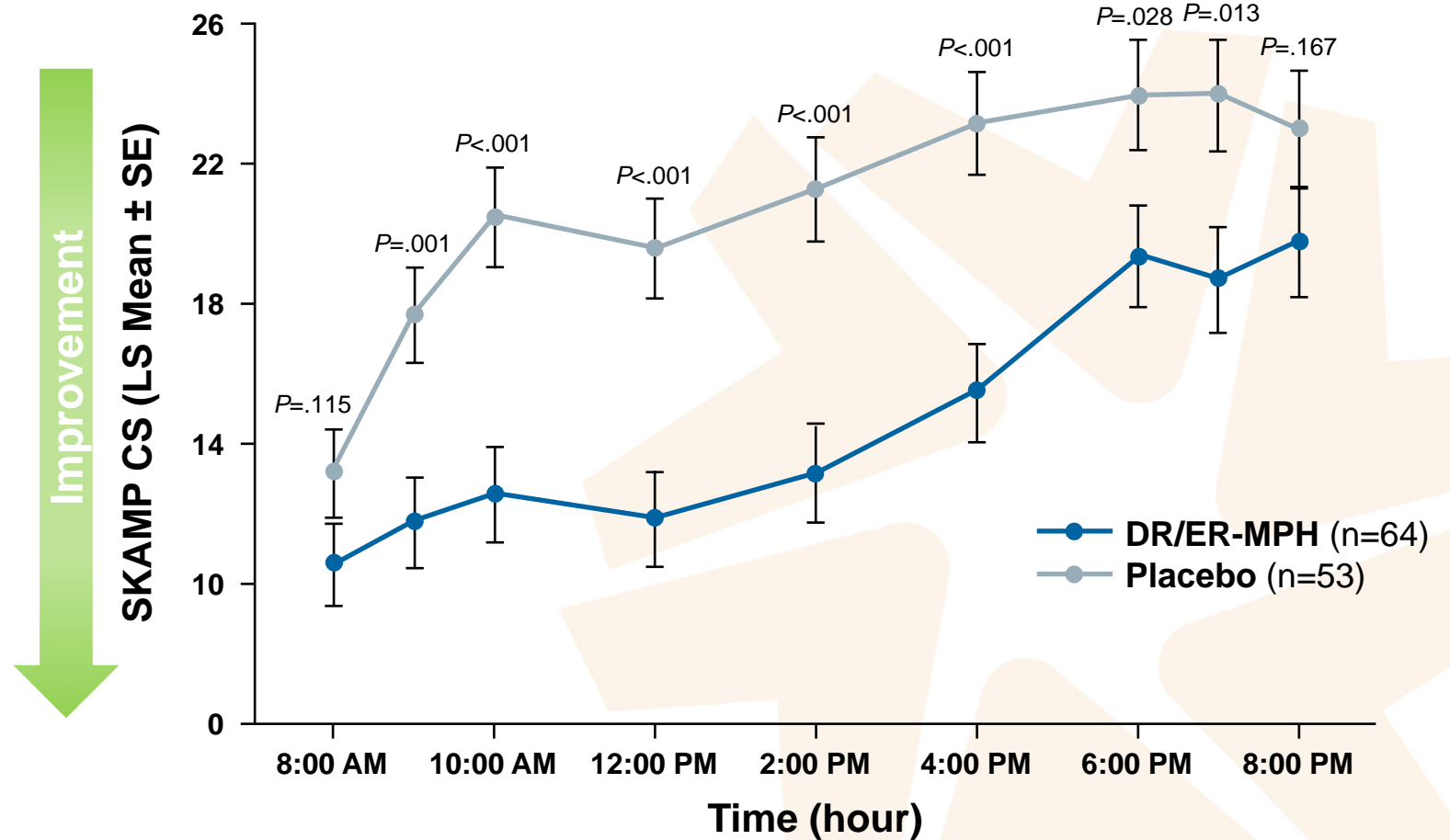

Another Innovative Approach: Combining Immediate Release MPH with a Pro-drug

- **3 Doses**
- **All of them are fixed in the 30% methylphenidate (MPH).**
- **- Immediate Release**
- **And 70% is Serdexmethylphenidate. (SDX) – extended release**
- Extended Release

20 mg	26.1 mg / 5.2 mg
30 mg	39.2 mg / 7.8 mg
40 mg	52.3 mg / 10.4 mg

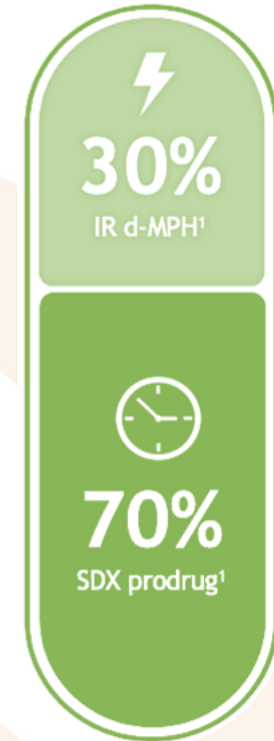

Combining Immediate Release MPH with a Pro-Drug MPH is a Successful ADHD Strategy

The pivotal trial was a multicenter, dose-optimized, double-blind, randomized, placebo-controlled, parallel-group, analog laboratory classroom study to determine the efficacy, safety, and tolerability of MPH (IR) + SDX (ER)

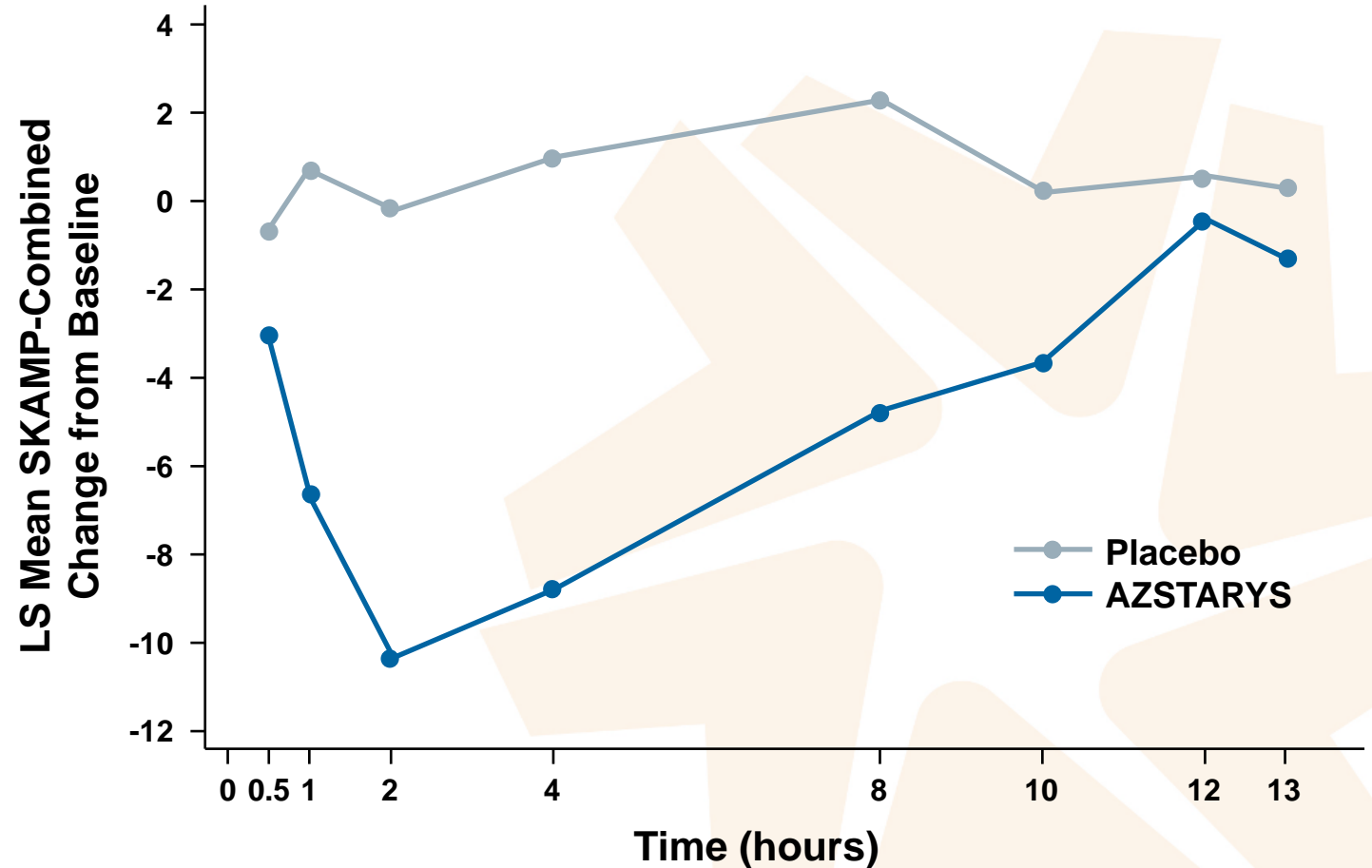

Novel Release Mechanism – a d-Amphetamine Patch for Children & Adults

- The FDA has approved the first amphetamine transdermal patch for treating attention-deficit/hyperactivity disorder (ADHD) among adults and children aged 6 years or older
- The dextroamphetamine patch is applied for up to 9 hours, takes effect after 2 hours, and remains effective for up to 12 hours. It is designed to give clinicians and patients more control over dosing time to better fit their schedules and optimize treatment benefits
- There are 4 doses available – 4.5 mg/9 hours; 9 mg/9 hours; 13.5 mg/9 hours; 18 mg/9 hours

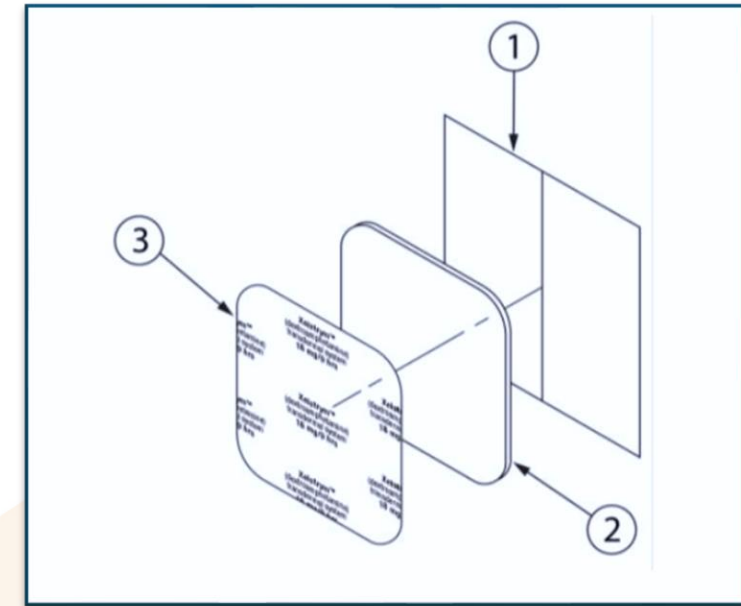

(1) oversized protective silicone-coated polyester release liner that is removed and discarded prior to application (2) acrylic adhesive matrix containing dextroamphetamine, and (3) polyester and polyurethane laminate film (backing).

D-ATS: Dextro-Amphetamine Transdermal System

Analog Classroom Study with 4 doses of d-ATS. 5 mg, 10 mg, 15 mg, and 20 mg. Dose optimization was achieved during a 5 week open label dose optimization period.

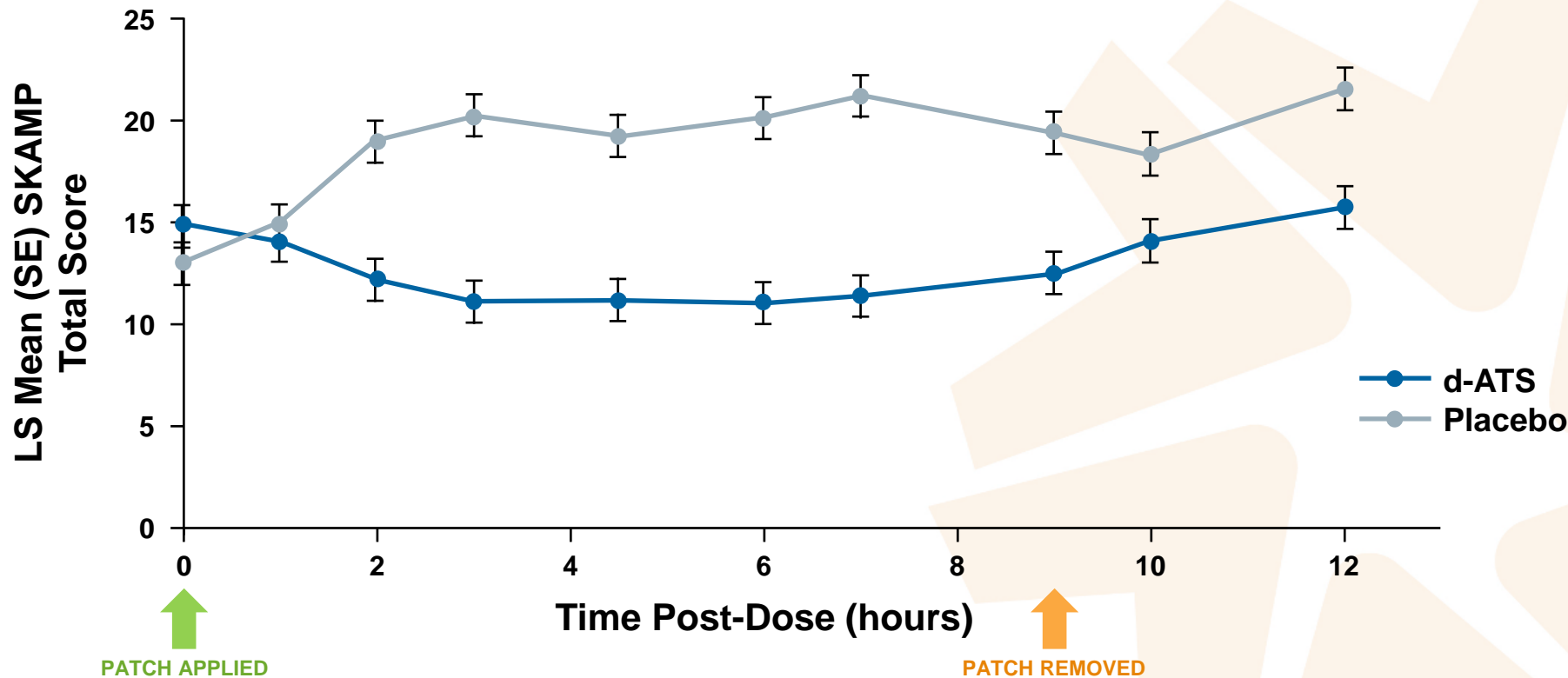

Time course of SKAMP total scores during laboratory classroom assessment (full analysis set).

* $P < .05$. † $P < .001$.

SKAMP = Swanson, Kotkin, Agler, M-Flynn, and Pelham Scale.

Cutler AJ et al. J Clin Child Adol Psychiatry 2022.32(2):89-97.

D-ATS: Wide Variety of Application Site Options

Step 1: Select the patch application site (see Figure B).

- Choose **1** application site, on either the left or right side, to apply **1** patch
 - chest
 - upper arm
 - upper back
 - flank (sides of the waist)
 - hip
- **Avoid areas of tight clothing**, such as waistbands or straps.
- Choose a **different application site** from the one used the previous day when you apply a **new patch**.
- Check the expiration date before applying the patch.

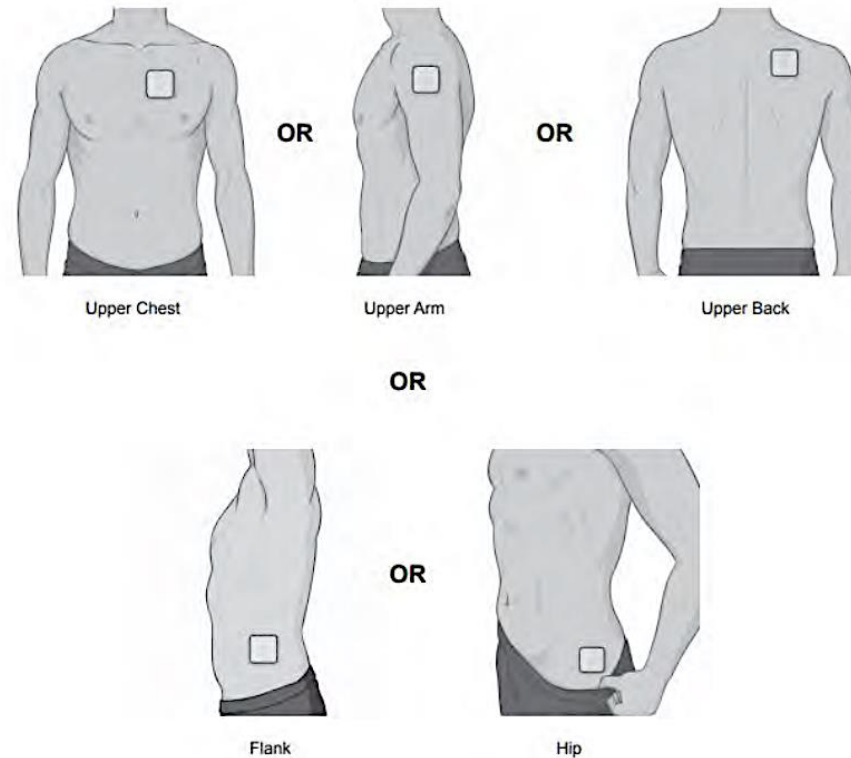

Figure B

Minimizing Risks of Stimulant Diversion & Coordinated Care of Adult ADHD



Stimulants Prescribed for ADHD Risk Factors for Misuse and Diversion

- **Rates of past year nonprescribed stimulant use:**
 - 5% to 9% of grade- and high-school age children
 - 5% to 35% of college-age individuals
- **Lifetime rates of diversion:**
 - 16% to 29% of students with prescriptions asked to give, sell, or trade medications
- **Risk Factors:**
 - White race
 - Membership in a fraternity or sorority
 - Lower grade point averages
 - Use of IR compared with ER preparations
 - Individuals with multiple ADHD symptoms

Stimulant Misuse and Abuse in Treated College Students

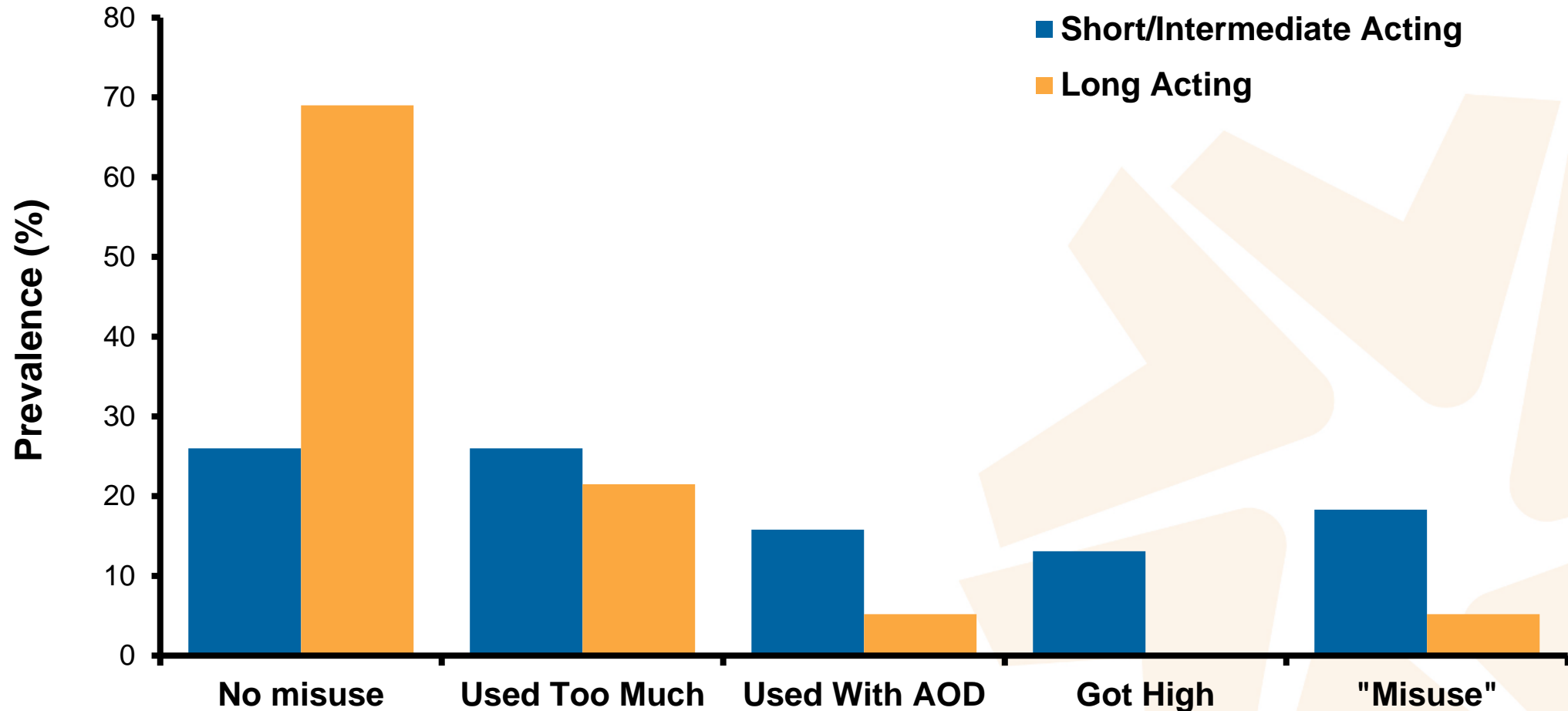

N = 55 past-year prescribed stimulant users from a random sample at a large Midwestern research university.

AOD = alcohol and other drugs

Sepulveda DR, et al. *J Pharm Pract.* 2011;24(6):551-560.

Stimulant Prescribing:

Managing the Risk of Stimulant Side Effects and Abuse

Pre-prescription:

Collect personal and family cardiovascular history. Take baseline pulse and blood pressure and monitor every 3–6 months.

Pre-prescription:

Evaluate patient for drug abuse history and diversion potential. Treat current SUD before ADHD, consider extended-release formulations when SUD history indicated.

Monitor BMI for change. Consider drug holiday or appetite-promoting agent if needed.

Evaluate sleep at baseline and at each visit, screen for RLS and sleep apnea. Adjust and/or add medication as needed.

Stimulant
Risk and Side Effect
Management
Strategies

Monitor for irritability and depression, reduce dose and psychoeducation as frontline interventions.

Monitor for new-onset tics. If worsening over 3 months, adjust medication regime (eg, add on alpha agonist or switch to non-stimulant).

Question to Pose to Ourselves –
What Exactly are We Trying to Optimize in the
Treatment of Adult ADHD?



The 24-Hour Day of a Typical Adult and Why the Adult with ADHD Needs Longer Coverage of Symptoms Every Day

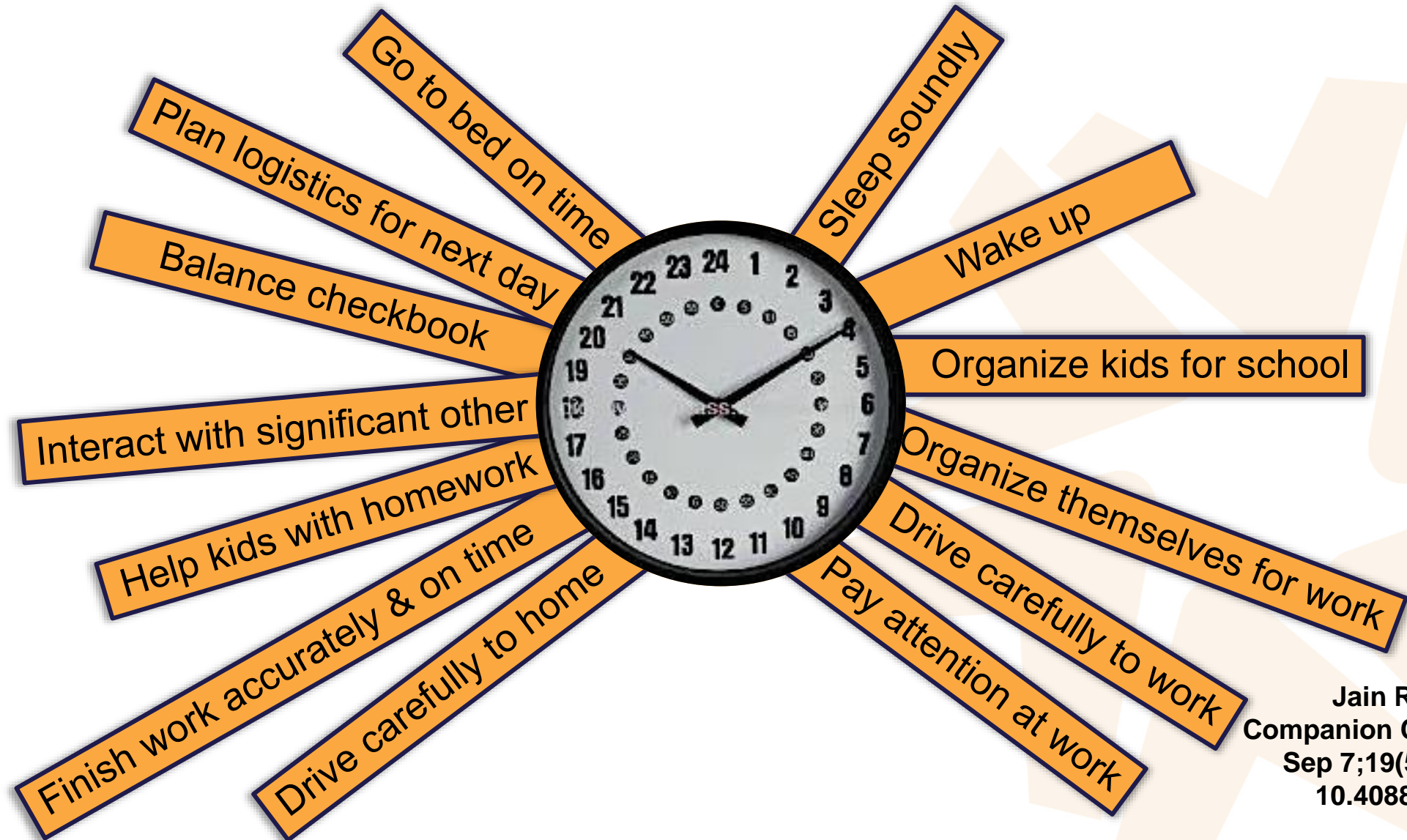

Answer: A number of things!

Top 4 are -

1. *Symptoms*
2. *Impairment*
3. *Functionality*
4. *Quality of Life*



Pharmacologic and Nonpharmacologic Treatment Options are Used for Treating Adult ADHD



Nonpharmacologic
treatment options^{1,2}

Coaching

Cognitive behavioral therapy

Dialectical behavioral therapy

Physical exercise

Mindful awareness practice



Pharmacologic
treatment options¹

Stimulants

Nonstimulants

All Symptoms and Challenges from Adult ADHD Should be Addressed

Diagnostic and Associated Features



Higher risks for traffic accidents or injury



Impaired Work Performance



Relationship Problems



Higher probability of unemployment



Difficulty completing tasks needing sustainability



Antisocial personality disorder

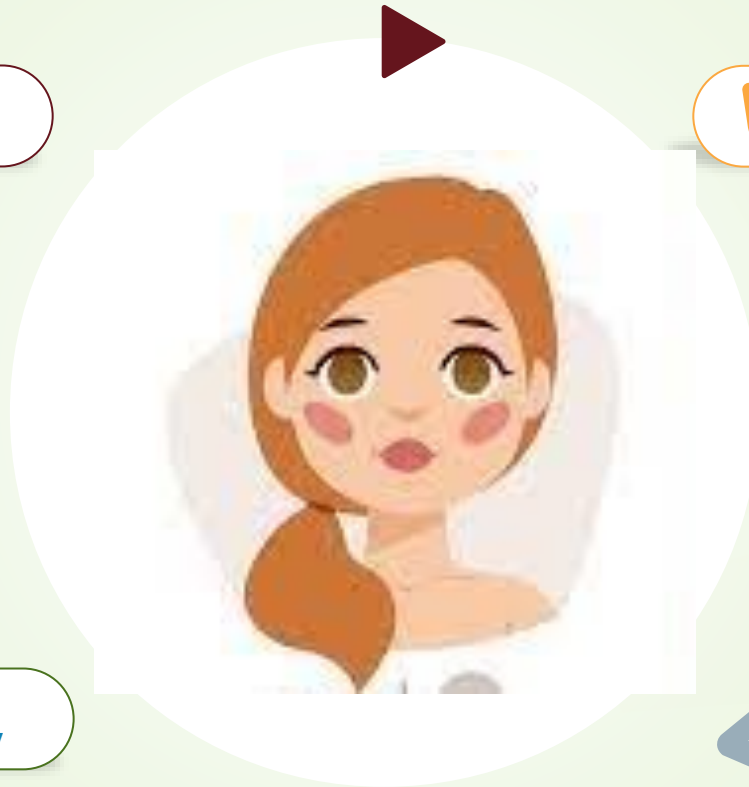

Optimizing ADHD Symptom Reduction Can Minimize Functional Impairment

ADHD-RS = 0–54 (18 symptoms rated 0 to 3)

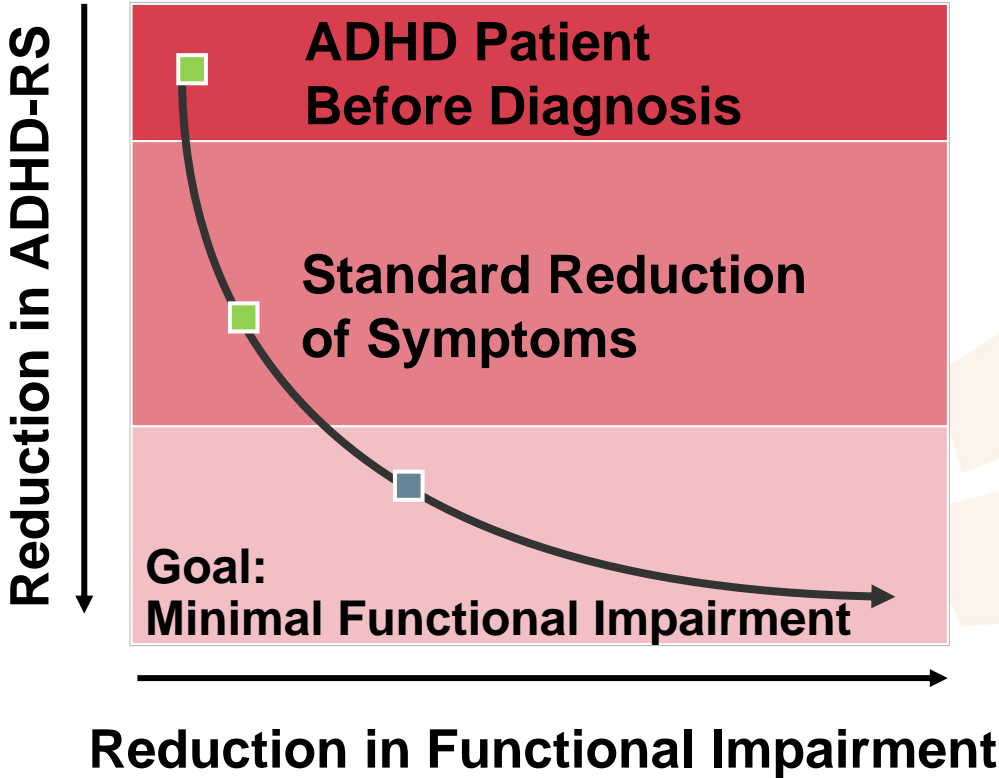

ADHD Diagnosis-
Average ADHD-RS = 30–40

Standard Reduction
Average ADHD-RS = 20–30

Optimal Improvement
Average ADHD-RS <18

How Do We Get There to Optimizing All of Our Adult ADHD Patients



A 5-step Process for Optimized Care of ADHD is Recommended

1. Confirm diagnosis of ADHD (and any and all co-morbidities!) confirmed using DSM-5 criteria and offer psychoeducation to the patient and the support system
2. Set clear goals before starting therapy – and the 4 goals of optimized adult ADHD care are - *1. Symptom reduction, 2. Impairment diminishment, 3. Functionality elevation, 4. Quality of Life enhancement*
3. Proactively establish optimized treatment of adult ADHD will always be non-pharmacological treatment, augmented by pharmacotherapy if indicated
4. Chose you ADHD treatment option with care – many options are available. Matching patient to right treatment option/s is critical
5. During follow-up, ask important questions about treatment benefits on symptoms and impairments

Team Approach is Ideal!

Involving All Relevant Patients is Ideal

Health Care Providers	
Professionals to collaborate with in monitoring for abuse/diversion and increasing adherence	<ul style="list-style-type: none">• Psychiatrist• Primary care physician• Psychologist/social worker/counselor• Psychometrician

The Benefits of Treating ADHD

- Treatment of adult ADHD with licensed medications may lead to benefits across a range of outcomes, including core symptoms, executive function, and quality of life, within a relatively short period of time
 - In a systematic analysis of 48 studies and 76 outcome measures in patients with ADHD, treatment of ADHD was associated with benefit in a number of areas

Treatment benefit by outcome group in treated patients with ADHD vs untreated ADHD

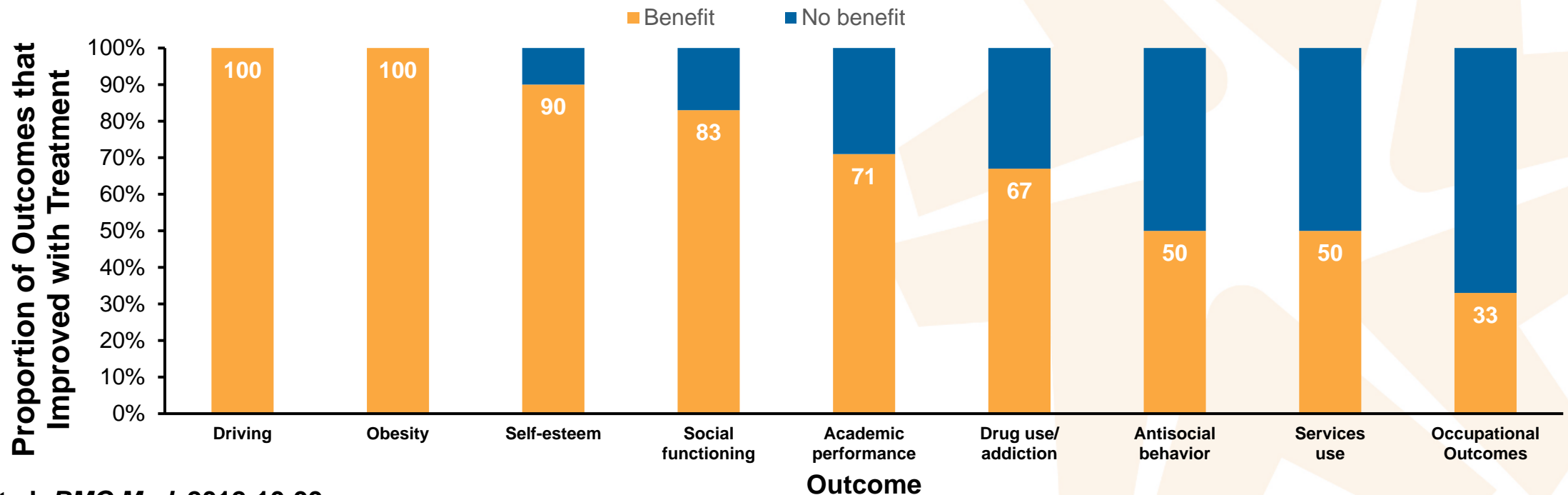

In Summary

3 Key Take Home Points -

ADHD prevalence among the adult patient population is **~4.4%**^{1,2,*}

Up to **60% of those diagnosed** with ADHD in childhood continue to have difficulties into adulthood³

>80% of adults with ADHD are currently not diagnosed and/or not receiving treatment⁴

*Data from the National Comorbidity Survey Replication (2001 to 2003) in adults aged 18 to 44 years of age.

1. National Institute of Mental Health. Attention-Deficit/Hyperactivity Disorder. <https://www.nimh.nih.gov/health/statistics/attention-deficit-hyperactivity-disorder-adhd>. Accessed July 21, 2021. 2. Culpepper L, Mattingly G. *Prim Care Companion J Clin Psychiatry*. 2010;12(6):PCC.10r00951. 3. Harpin VA. *Arch Dis Child*. 2005;90 Suppl 1(Suppl 1):i2-i7. 4. Ginsberg Y et al. *Prim Care Companion CNS Disord*. 2014;16(3):PCC.13r01600.



Q&A